



HITACHI

SERVICE MANUAL

TK

No. 1614E

TRK-9900E, E(BS)

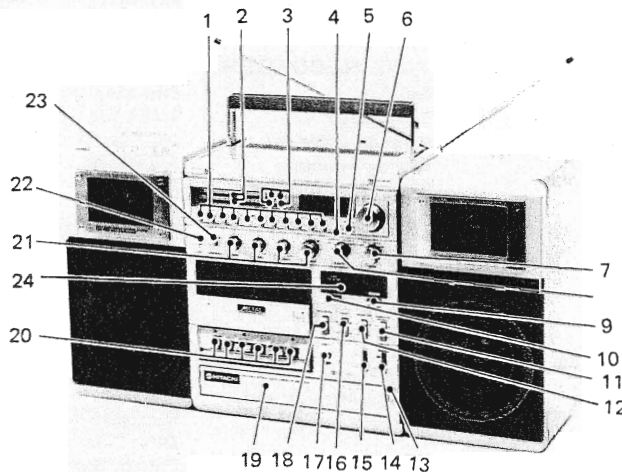

CONTENTS

Specifications	2
Disassembly	2
Adjustments	6
Dial cord stringing	9
Inspection of mechanism	10
Lubrications	10
Replacement parts list	11
Exploded view	15
Schematic diagram	18
Circuit board diagram	21
Wiring diagram	34
Block diagram	37

KEY TO ILLUSTRATIONS

- | | |
|---|---|
| 1. Clock operation/Frequency/FM preset channel switches | 12. Dolby NR switch |
| 2. Level indicators | 13. Panel release button |
| 3. FM stereo/Dolby NR/Operation/Battery/Tuning indicators | 14. Power switch |
| 4. FM manual tuning switch | 15. Tape select switch |
| 5. AFC switch | 16. Mode switch |
| 6. Tuning control | 17. Eject button |
| 7. Band selector | 18. Rec. mute switch |
| 8. Function selector | 19. Control box |
| 9. Program switch | 20. Tape function buttons |
| 10. Counter reset button | 21. Volume/Bass/Treble/Balance controls |
| 11. FM mute switch | 22. Light switch |
| | 23. Loudness switch |
| | 24. AC power indicator [E (BS) only] |

SAFETY PRECAUTION

The following precautions should be observed when servicing.

1. Since many parts in the unit have special safety-related characteristics, always use genuine Hitachi's replacement parts. Especially critical parts in the power circuit block should not be replaced with other makes. Critical parts are marked with \triangle in the schematic diagram, and circuit board diagram.
2. Before returning a repaired unit to the customer, the service technician must thoroughly test the unit to ascertain that it is completely safe to operate without danger of electrical shock.

SPECIFICATIONS AND PARTS ARE SUBJECT TO CHANGE FOR IMPROVEMENT

FM/SW/MW/LW RADIO CASSETTE TAPE RECORDER

Aug. 1981

TOKAI WORKS

SPECIFICATIONS

GENERAL SECTION

Semi-conductors:	LCD Module : 1 ICs : 17 Transistors : 57 FET : 1 Diodes: 64(E), 66 [E(BS)] LEDs : 4(E), 5[E(BS)] LED Module : 1 Varistor : 1 Varicaps : 4
Power (Mains) Supply:	AC: 220V, 50Hz (E) 240V, 50Hz [E(BS)] DC: 15V (IEC R20 x 10 or equivalent) 1.5V (IEC R6x1) for display Car: Use car battery lead
Power (Mains) Consumption:	82W(E), 102W[E(BS)]
Power output:	50W M.P.O. (AC operation) 7.5W/CH (10% T.H.D. DC)
Speaker:	12cm, 3.2 ohms x 2 5cm, 4 ohms x 2
Dimensions:	58.2 (W) x 30.0 (H) x 23.3 (D) cm
Weight	13.3 kg (with batteries)

TUNER SECTION

Circuit System	FM/SW/MW/LW 4-band superheterodyne
Tuning Range:	FM: 87.5 to 108MHz SW: 6 to 18MHz MW: 530 to 1605kHz LW: 150 to 350kHz
Sensitivity:	FM: 8dB (pra.), 0dB (max.) SW: 25dB (pra.), 20dB (max.) MW: 45dB (pra.), 30dB (max.) LW: 52dB (pra.), 40dB (max.)

Intermediate Frequency:

FM: 10.7 MHz
SW/MW/LW: 468kHz

Antennas (Aerials):

FM: Telescopic antenna or External antenna
SW: Telescopic antenna
MW/LW: Ferrite-core antenna

TAPE RECORDER

Tape:	Cassette tape (C-30, 60, 90)
Tape Speed:	4.75 cm/s
Recording System:	AC bias, 57 kHz
Erasing System:	AC erasing
Frequency Response:	METAL; 20 to 17,000 Hz CrO ₂ ; 20 to 16,000 Hz Normal; 20 to 15,000 Hz

S/N (Signal to Noise Ratio):

62 dB (Dolby NR ON)

Wow & Flutter:

0.05% (WRMS)

Cross Talk:

Between tracks: 50 dB
Between channels: 25 dB
65 dB

Erase Ratio:

Input sensitivity and Impedance:

Microphone: 0.8mV, 1 k ohms
DIN: 2.3mV, 4.6 k ohms
Phono: 3mV, 50 k ohms

Output Level and

Load Impedance:

DIN: 775mV, 1 k ohms
Headphone: 8 ohms or more
Ext. speaker: 3.2-8 ohms

Fast Forward or

Rewinding Time:

100 sec (Using C-60)

Distortion:

2%

Motor:

DC micromotor

DISASSEMBLY

1. Rear Case

- 1) Remove (A) (eight) screws.
- 2) Remove lead wires of the antenna terminal, battery terminal and power supply PC board.

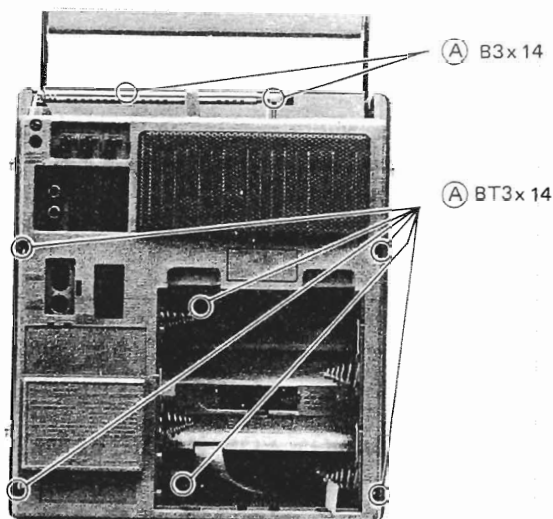

Fig. 1

2. Power Supply PC Board

- 1) Remove (B) connector.
- 2) Remove (C) (one) screw.

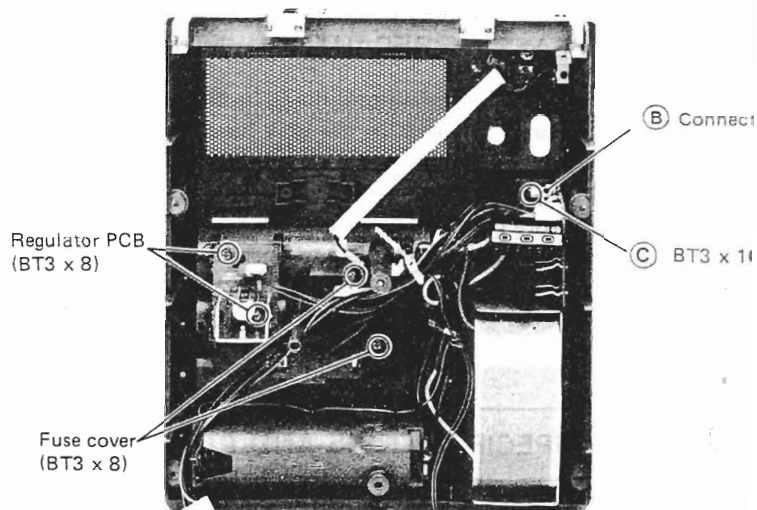

Fig. 2

Power Transformer Installation

Install the power transformer shown in Fig. 3.

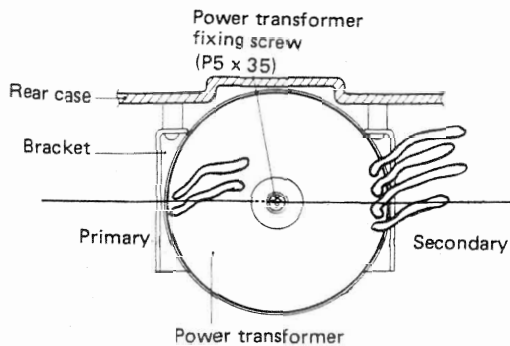

Fig. 3

3. Function Button Assembly

Push up the function button assembly in the direction of the arrow to remove the stopper, and then remove the function button assembly toward the front.

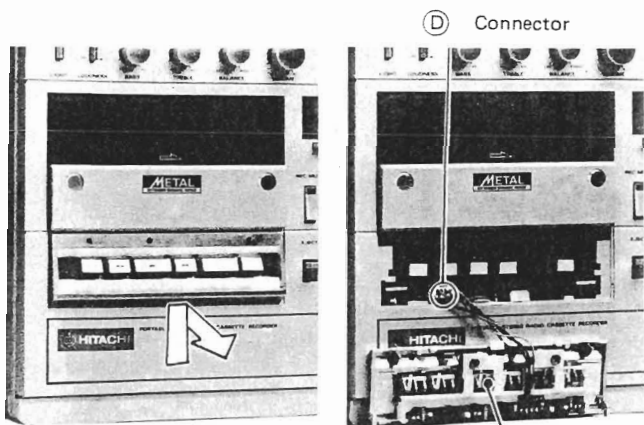

Fig. 4

Fig. 5

4. Cassette Lid

Remove the function button assembly and press the eject button to open the cassette lid.

Push the cassette lid arm in the direction of the arrow to remove the cassette lid. When installing the cassette lid, engage the cassette lid to the damper gear. Then, press the eject button to push up the eject slider and gradually close the cassette lid.

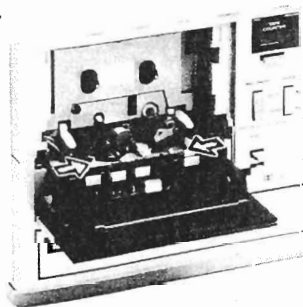

Fig. 6

5. Chassis Assembly

- 1) Remove eleven knobs (Tuning, Bass, Treble, Balance, Volume, Function, Band, Tape, Power, REC Volume L/R).
- 2) Remove (E) (five) screws.
- 3) Remove (D) connector shown in Fig. 5 and speaker lead wires.
- 4) Open the cassette lid and pull out the chassis assembly in the direction of the arrow.

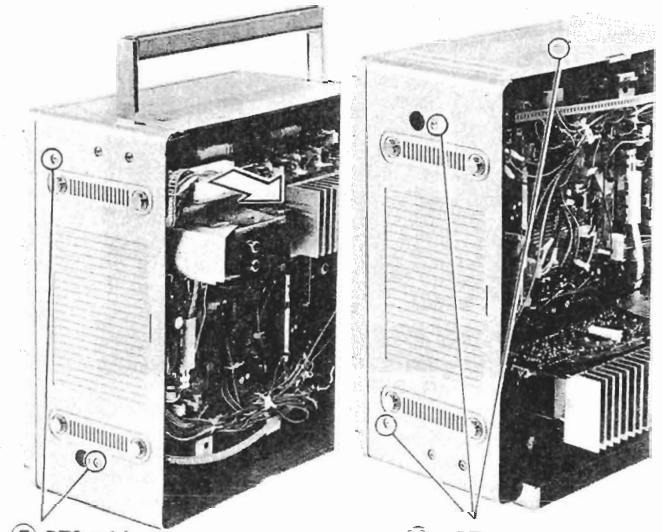

Fig. 7

Fig. 8

6. Radio PC Board

- 1) Remove (F) (three) screws.
- 2) Remove the switch wire of the band select switch and open the PC board.

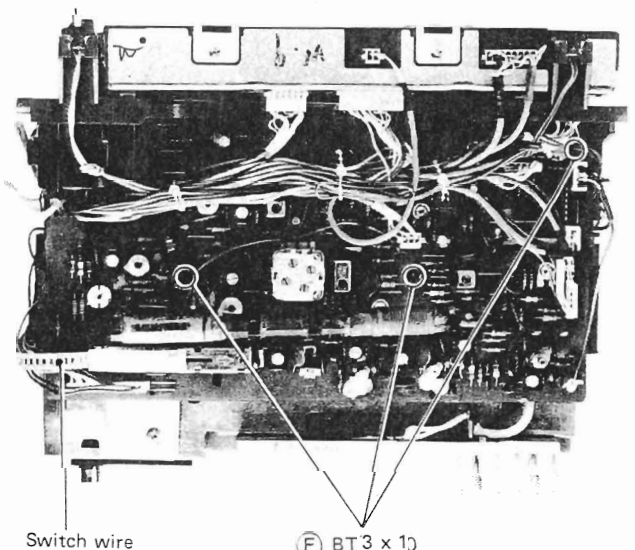
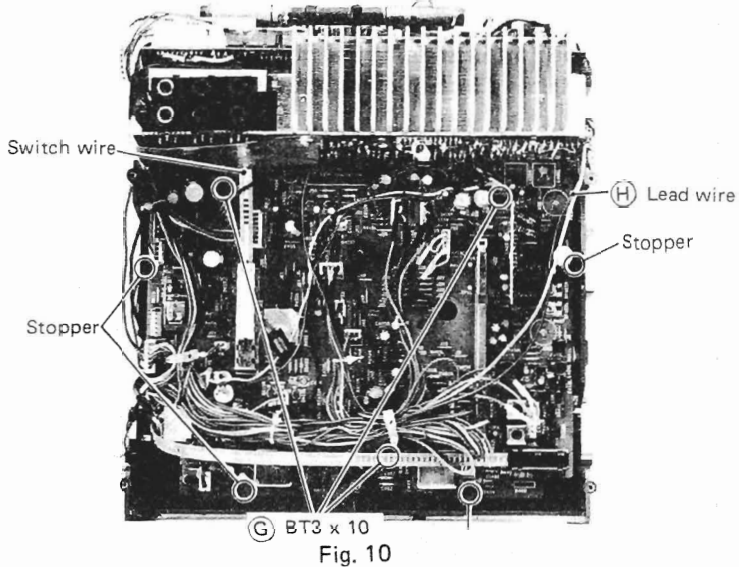

Fig. 9

7. Audio PC Board

- 1) Remove ⑥ (three) screws.
- 2) Remove the switch wire of the function selector switch and ⑦ lead wires.
- 3) Push the four stoppers and open the PC board.



8. Phono/Main amp PC Board

Remove ① (two) screws.

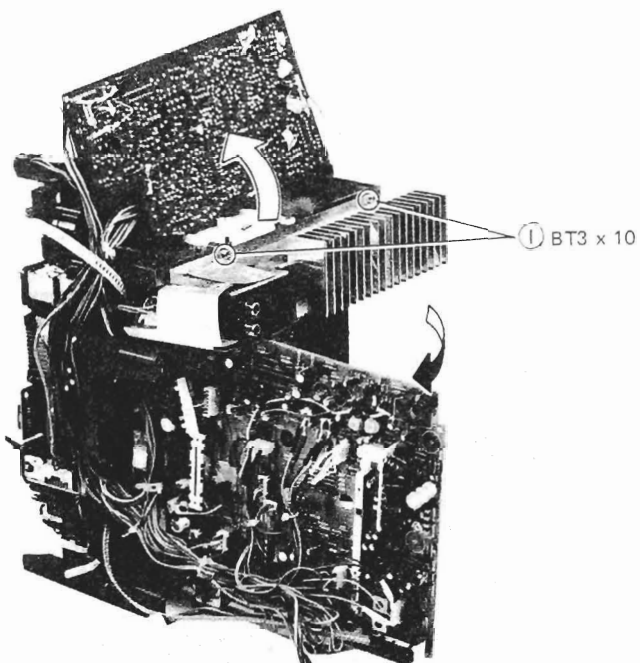

9. Control PC Board

- 1) Remove ④ (four) LED holder fixing screws.
- 2) Pull out the LCD module toward the front.
- 3) Remove ⑤ (two) screws and rear side connectors.

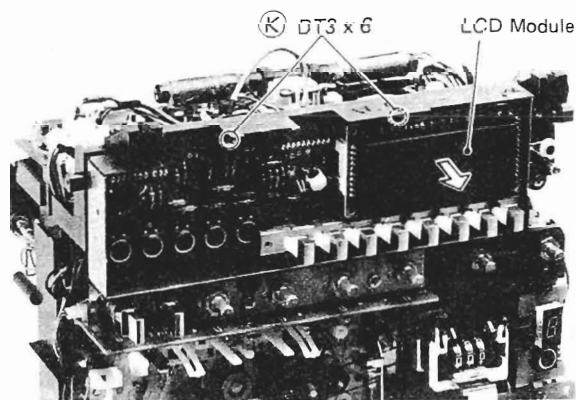
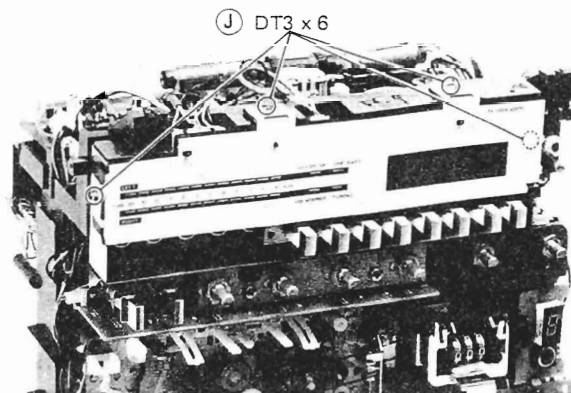

10. Volume PC Board

Remove ② (two) screws.

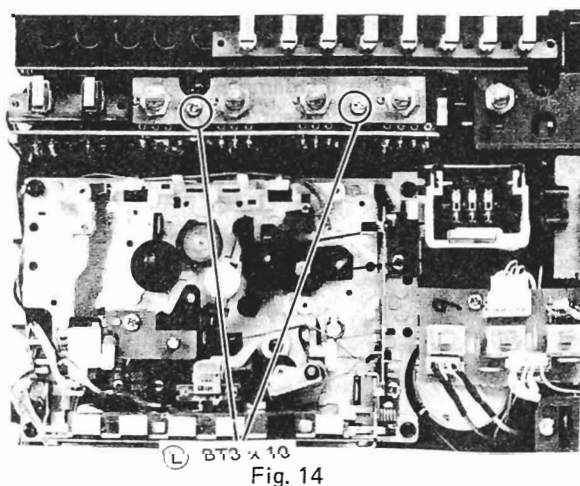

11. DRPS PC Board

- 1) Remove (M) (two) screws fixing switch PC board.
- 2) Push the two stoppers and remove the DRPS indicator PC board.
- 3) Pull out the DRPS PC board toward the front.

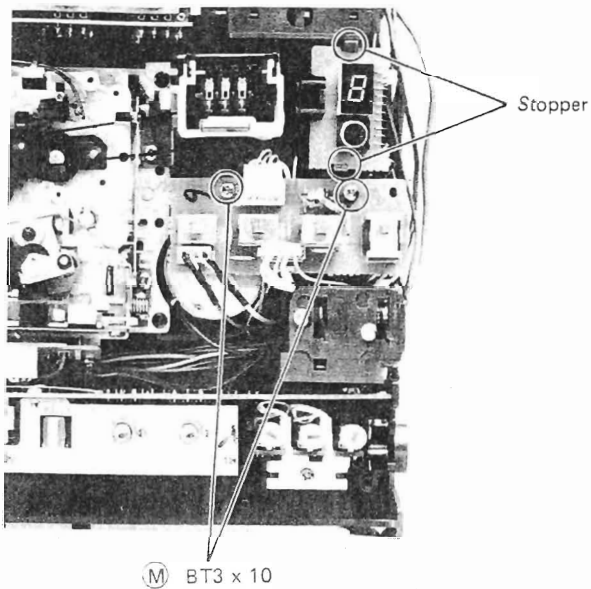

Fig. 15

13. Mic amp/Jack PC Board

- 1) Remove (O) (one) screw fixing preset volume PC board.
- 2) Remove (P) (four) screws.

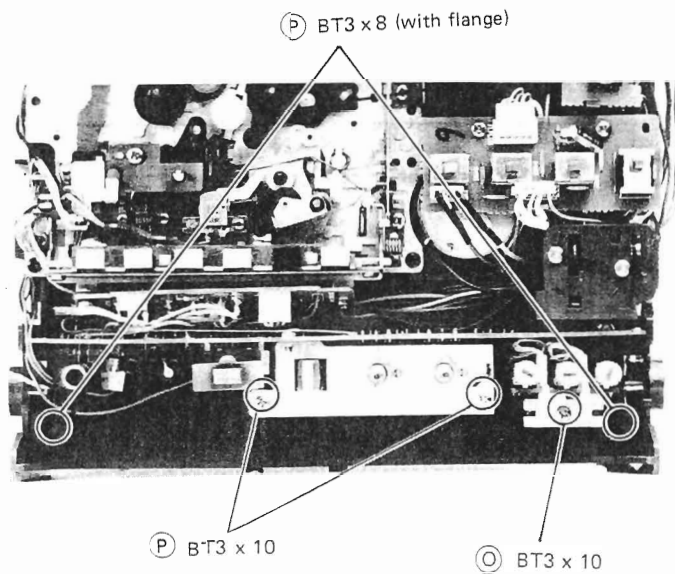

Fig. 17

12. Cassette Chassis

- 1) Remove (M) (two) screws fixing switch PC board shown in Fig. 15.
- 2) Remove (N) (four) screws.

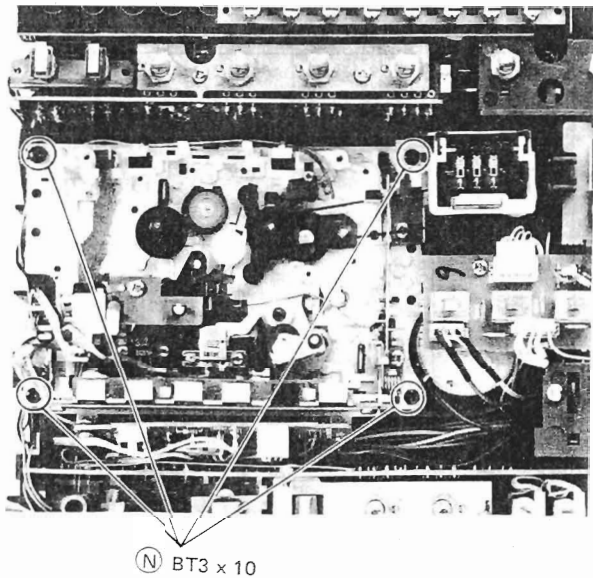
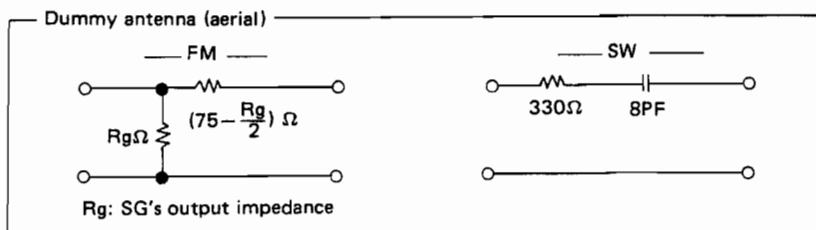

Fig. 16

ADJUSTMENTS

1. Tuner Section



Step	Adjustment Item	Measuring Instrument and Connection			Genescope or Signal Generator Frequency	Display Frequency	Adjust	Reading
		Measuring Instrument	Input Terminal	Output Terminal				
1	(1) FM IF	Turn T202 fully counterclockwise.						
	(2) S-Curve	• Genescope (10.7 MHz)	TP101	TP301	10.7 MHz	Highest	T101 T202	Note 1 Note 2
2	(1) FM VCO voltage	Turn RT101 fully clockwise.						
	(2)	• DC volt meter (High impedance)	—	TP102	—	Lowest	RT102	2.0V (Note 3)
	(3)					—	RT101	2.0V (Note 4)
3	(1) FM OSC. (Covering)	—	—	—	—	Lowest	L104	87.5 MHz (Note 5)
						Highest	CT103	109 MHz (Note 6)
						Repeat steps (1) and (2).		
4	(1) FM ANT. (Tracking)	• FM signal generator (400Hz, 30% mod.) • Oscilloscope • VTVM	TP103 (thru FM dummy antenna)	Speaker terminal (3.2Ω load)	90 MHz	90 MHz	L101 L102	Max. output
						106 MHz	CT101 CT102	
						Repeat steps (1) and (2).		
5	(1) FM MPX (Multiplex)	• Frequency counter	Connect a 10μF 25V electrolytic capacitor between the No. 2 pin of IC301 and ground.	TP302	—	—	RT302	19 kHz ± 100 Hz (Note 7)
6	(1) FM Stereo Separation	• FM stereo signal generator [98MHz, L+R (1kHz): 30% mod. Pilot(19kHz); 10% mod., 60dB] • Oscilloscope • VTVM	TP103 (thru FM dummy antenna)	Speaker terminal (3.2Ω load)	98MHz	98 MHz	RT301	Note 8
7	(1) AM IF	• Genescope (468kHz)	Ferrite antenna (thru loop antenna)	TP201	468 kHz	Highest	T151 T201	Note 9
	(2)	Repeat step (1)						
8	(1) SW OSC. (Covering)	—	—	—	—	Lowest	L154	5.8 MHz (Note 5)
						Highest	CT154	18.5 MHz (Note 6)
						Repeat steps (1) and (2).		

2. Tape Recorder Section

Perform the following adjustments in the sequence stated after cleaning the head, pressure roller, and capstan with a head cleaning stick moistened in alcohol.

Also, unless specially indicated otherwise, set the switches and controls to the positions indicated in the table.

Symbol No.	Switches and Controls	Position	Symbol No.	Switches and Controls	Position
S402	Function selector	TAPE	S410	Recording mode selector	MANUAL
S403	Tape select switch	NORMAL	RV406L, R	Recording level controls	MAX.
S407	Dolby NR switch	OFF			

Step	Adjustment Item	Measuring Instrument and connection			Check Tape	Mode	Adjusted Position	Adjusted Value	Remarks
		Measuring Instrument	Input Terminal	Output Terminal					
1	Tape speed	• Frequency counter	—	DIN socket (output)	MTT-111, 3,000 Hz	Playback	Semivariable resistor in the motor	3000 Hz +90 Hz -10 Hz	Note 1
2	Head azimuth	• VTVM	—	DIN socket (output)	MTT-316 or 216, 12.5 kHz	Playback	Azimuth adjusting screw	Output Max.	Note 2
3	Playback gain	• VTVM	—	TP401L, R	MTT-150, 400 Hz 20m Maxwell	Playback	RT402L, R	0.775V (0 dBm)	Note 3
4	Level indicator						RT404L, R	0 dB	Note 4
5	(1) Bias leakage	Set the tape select switch to METAL position.							
		(2)	• VTVM	—	TP402L, R	—	Record	L403L, R	Output Min.
6	(1) Bias current	Set the tape select switch to METAL/CrO ₂ /NORMAL position.							
		(2)	• VTVM	—	Both ends of 10Ω resistor	—	Record	RT401L, R	METAL: 680±50μA CrO ₂ : 430±50μA NORMAL: 370±50μA
7	Record/playback output level	• Audio oscillator (400 Hz) • VTVM	DIN socket (input)	TP401L, R	NORMAL tape	Record/playback	RT403L, R	0.775V ± 1dB	Note 7
8	Record/playback frequency characteristics	• Audio oscillator (1.25 kHz/12.5 kHz) • Attenuator • VTVM	DIN socket (input)	TP401L, R	NORMAL tape	Record/playback	RT401L, R	Output difference within. ± 2 dB	Note 8
9	DRPS operation level	—	—	—	TMT-6261, 500 Hz -40 dB/-35 dB	Playback	RT701		Note 9

Step	Adjustment Item	Measuring Instrument and Connection			Genescope or Signal Generator Frequency	Display Frequency	Adjust	Reading
		Measuring Instrument	Input Terminal	Output Terminal				
9	SW ANT (Tracking)	<ul style="list-style-type: none"> • AM signal generator (400 Hz, 30% mod.) • VTVM 	TP103 (thru SW dummy antenna)	Speaker terminal (3.2Ω load)	6.5MHz	6.5MHz	L151	Max. output
					16MHz	16MHz	CT151	
					Repeat steps (1) and (2).			
10	MW OSC. (Covering)	-	-	-	-	Lowest	L155	515 kHz (Note 5)
						Highest	CT155	1650 kHz (Note 6)
						Repeat steps (1) and (2).		
11	MW ANT. (Tracking)	<ul style="list-style-type: none"> • AM signal generator (400 Hz, 30% mod.) • VTVM 	Ferrite antenna (thru loop antenna)	Speaker terminal (3.2Ω load)	600 kHz	600 kHz	L152	Max. output
					1400kHz	1400kHz	CT152	
					Repeat steps (1) and (2).			
12	LW OSC. (Covering)	-	-	-	-	Lowest	L156	145 kHz (Note 5)
						Highest	CT156	360 kHz (Note 6)
						Repeat steps (1) and (2).		
13	LW ANT. (Tracking)	<ul style="list-style-type: none"> • AM signal generator (400 Hz, 30% mod.) • VTVM 	Ferrite antenna (thru loop antenna)	Speaker terminal (3.2Ω load)	160kHz	160 kHz	L153	Max. output
					330 kHz	330 kHz	CT153	
					Repeat steps (1) and (2).			

Note:

1. Feed in a weak signal to TP101 from the genescope. Adjust T101 for maximum gain and the wave form indicated in Figure 18. If the center of the wave form cannot be lined up on the marker, adjust the right/left balance.
2. Use the T202 core to form the S-curve shown in Figure 19. Adjust the symmetry of A and B about point C for linearity.
3. Turn the tuning control fully counterclockwise and adjust RT102 so that the voltages of TP102 becomes 2.0V.
4. Set the FM preset channel switches to CH-1 and turn the FM preset adjustment knob (CH-1) to fully counterclockwise. Then, adjust RT101 so that the voltages of TP102 becomes 2.0V.
5. Turn the tuning control fully counterclockwise and adjust LXXX so that the frequency display becomes specified value.
6. Turn the tuning control fully clockwise and adjust CTXXX so that the frequency display becomes specified value.
7. Connect the frequency counter to TP302 via a resistor of 100 kΩ.
8. Feed the signal for each channel and adjust RT301 so that an optimum separation can be obtained.
9. Feed in a weak signal from the genescope. Adjust T151 and T201 for maximum gain and the waveform of Figure 20.

Adjust the genescope output so that there is a little noise riding on the leading edge.

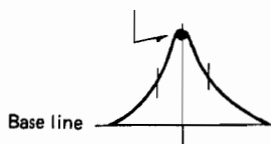

Fig. 18

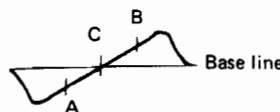

Fig. 19

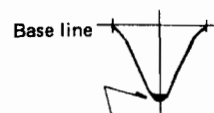

Fig. 20

Note:

1. Adjust within 30 sec. after heat-running for more than 20 minutes.
2. When the maximum values of both channels are different, tune to the maximum value of the L channel. In this case, the difference between the maximum values of both channels should be within 2 dB.
3. Playback a test tape (MTT-150, 400 Hz 20 m Maxwell) and adjust RT402L, R so that the level of TP401L, R becomes 0.775V (0 dBm).
4. With the condition shown in step 3, adjust RT404L, R so that the level indicator lamp (0 dB) lights up.
5. Set the tape select switch to METAL position and adjust L403L, R so that the level of TP402L, R becomes minimum in the recording mode.
6. Connect a 10Ω resistor between the ground side of the record/playback head and ground. Connect the VTVM to both ends of this resistor and adjust RT401L, R so that the bias current as below.

Tape select switch position	Bias current
METAL	680 ± 50μA
CrO ₂	430 ± 50μA
NORMAL	370 ± 50μA

7. 1) Feed a 400Hz signal to the DIN socket (input) in the recording mode and adjust the record level controls so that the level of TP401L, R becomes 0.775V.
2) Record the signal on NORMAL tape with the conditions of item 1).
3) Playback the recorded signal and adjust RT403L, R so that the level of TP401L, R becomes 0.775V ± 1 dB.
8. 1) Feed a 1.25kHz signal to the DIN socket (input) in the recording mode and adjust the record level controls so that the level of TP401L, R becomes 0.775V. Then, adjust the attenuator to lower the output level by 20 dB.
2) Record the signal on NORMAL tape with the conditions of item 1), then continue to record with the audio oscillator frequency set to 12.5 kHz.
3) Playback the recorded signal and adjust RT401L, R so that the output level difference between two frequencies is within ±2 dB.
9. Load the test tape TMT-6261 (500 Hz, -35dB/-40dB) and set the unit to the DRPS mode from the playback mode. Adjust RT701 so that the cueing function is stop at the 500Hz, -35 dB section and cueing function is continued at the 500Hz, -40 dB section.

DIAL CORD STRINGING

Stringing Method

1. Turn the pulley fully clockwise.
2. String the dial cord in the direction of arrow (No.1-12).

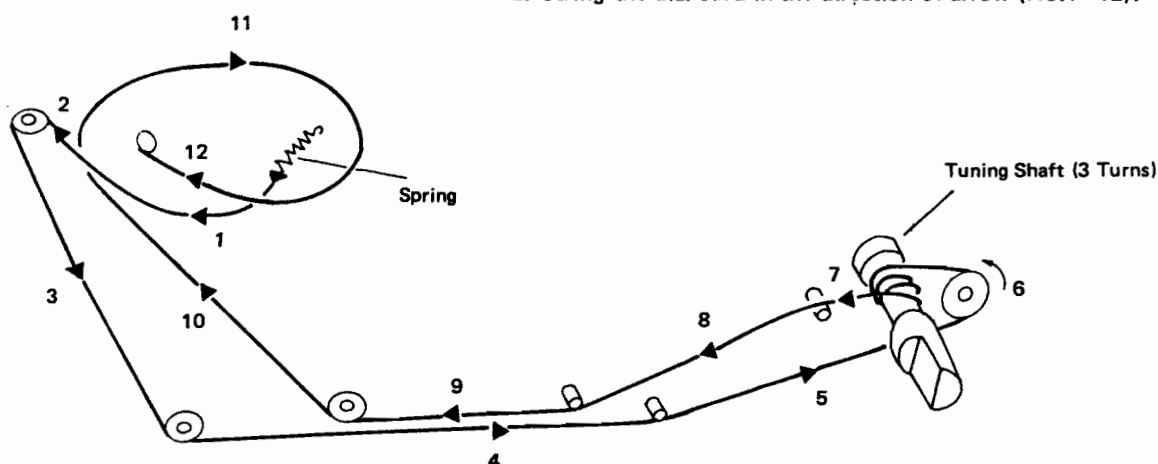

INSPECTION OF MECHANISM

Item No.	Inspection item	Reference value	Remarks
1	Pressure of pressure roller	350 ± 50 g	Note 1
2	Take-up torque	33 ~ 65 g.cm	
3	FF torque	70 ~120 g.cm	
4	REW torque	70 ~120 g.cm	
5	Supply side back-tension	1 ~ 3 g.cm	Without counter
6	Take-up side back-tension	6 g.cm	With counter
7	Brake force	10 g.cm or more	
8	PLAY, REC, FF, REW, PAUSE, STOP, EJECT	0.5 kg or less	
9	Flywheel thrust gap	0.05 ~0.5mm	

Note 1

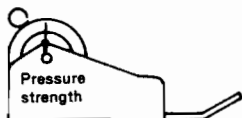

LUBRICATIONS

Lubricate one or two drops of oil to rotating point or lubricate grease to sliding point.

Lubricate the respective parts listed once every 1000 hours or once a year under normal conditions of use.

Avoid oiling them excessively, or rotation may become irregular because of oil splashes.

Lubrication		Oil or Grease
Rotary section	Metal and metal	Pan motor oil (10W-40)
	Mold and metal	Sonic slider oil (#1600)
Sliding section	Metal and metal	Hitasol (MO-138)
	Mold and mold	White grease (FL-LUBE-A)
	Mold and metal	
Spring resonance prevention		Froil (GB-TS-1)

REPLACEMENT PARTS LIST

SYMBOL-NO	P-NO	DESCRIPTION	SYMBOL-NO	P-NO	DESCRIPTION
CAPACITORS			C401LR	0209005	CERAMIC (RESISTOR SHAPE) 390PF+-10%
CT101-103	5058191	TRIMMER 10PF	C403LR	0208129	CERAMIC (RESISTOR SHAPE) 10PF+-5%
CT151	5058191	TRIMMER 10PF	C404LR	0209010	CERAMIC (RESISTOR SHAPE) 1000PF+-10%
CT152	5056111	VARIABLE CAPACITOR	C414LR	0209010	CERAMIC (RESISTOR SHAPE) 1000PF+-10%
CT153	5058191	TRIMMER 10PF	C415LR	0209003	CERAMIC (RESISTOR SHAPE) 270PF+-10%
CT154	5058191	TRIMMER 10PF	C422LR	0209026	CERAMIC (RESISTOR SHAPE) 0.01MF+-30%
CT155	5056111	VARIABLE CAPACITOR	C431LR	0209022	CERAMIC (RESISTOR SHAPE) 0.0022MF
CT156	5058102	VARIABLE CAPACITOR	C440LR	0209003	CERAMIC (RESISTOR SHAPE) 270PF+-10%
CV151	5056111	VARIABLE CAPACITOR	C442	0209008	CERAMIC (RESISTOR SHAPE) 680PF+-10%
CV152	5056111	VARIABLE CAPACITOR	C443	0209023	CERAMIC (RESISTOR SHAPE) 3300PF+-30%
C109	0208122	CERAMIC (RESISTOR SHAPE) 1.5PF+-5%	C451LR	0209025	CERAMIC (RESISTOR SHAPE) 6800PF+-30%
C111	0209026	CERAMIC (RESISTOR SHAPE) 0.01MF+-30%	C474LR	0209002	CERAMIC (RESISTOR SHAPE) 220PF+10%
C112	0209026	CERAMIC (RESISTOR SHAPE) 0.01MF+-30%	C495LR	0209026	CERAMIC (RESISTOR SHAPE) 0.01MF+-30%
C114	0209027	CERAMIC (RESISTOR SHAPE) 0.01MF+-30%	C523LR	0209024	CERAMIC (RESISTOR SHAPE) 4700PF+-30%
C117	0208162	CERAMIC (RESISTOR SHAPE) 18PF+-10%	C706	0256362	TANTALUM ELECTROLYTIC 0.22MF+-10X35V
C120	0209026	CERAMIC (RESISTOR SHAPE) 0.01MF+-30%	C708	0209026	CERAMIC (RESISTOR SHAPE) 0.01MF+-30%
C121	0208126	CERAMIC (RESISTOR SHAPE) 5.6PF+-5%	C710	0209022	CERAMIC (RESISTOR SHAPE) 0.0022MF
C122	0208129	CERAMIC (RESISTOR SHAPE) 10PF+-5%	CV101	5056111	VARIABLE CAPACITOR
C124	0209027	CERAMIC (RESISTOR SHAPE) 0.01MF+-30%	RESISTORS		
C159	0209026	CERAMIC (RESISTOR SHAPE) 0.01MF+-30%	RC601-604	0186451	CR PACK
C161	0208141	CERAMIC (RESISTOR SHAPE) 100PF+-5%	RT101	5007474	SEMI VARIABLE 1K OHM
C163	0209026	CERAMIC (RESISTOR SHAPE) 0.01MF+-30%	RT102	5007476	SEMI VARIABLE 5K OHM
C164	0209027	CERAMIC (RESISTOR SHAPE) 0.01MF+-30%	RT201	5007477	SEMI VARIABLE 10K OHM
C165	0209010	CERAMIC (RESISTOR SHAPE) 1000PF+-10%	RT301	5007472	SEMI VARIABLE 200 OHM
C166	0209026	CERAMIC (RESISTOR SHAPE) 0.01MF+-30%	RT302	5007477	SEMI VARIABLE 10K OHM
C167	0209026	CERAMIC (RESISTOR SHAPE) 0.01MF+-30%	RT401LR	5007482	SEMI VARIABLE 250K OHM
C171	0209027	CERAMIC (RESISTOR SHAPE) 0.01MF+-30%	RT402LR	5007477	SEMI VARIABLE 10K OHM
C175-177	0209027	CERAMIC (RESISTOR SHAPE) 0.01MF+-30%	RT403LR	5007478	SEMI VARIABLE 20K OHM
C201	0209026	CERAMIC (RESISTOR SHAPE) 0.01MF+-30%	RT404LR	5007192	SEMI VARIABLE 470K OHM
C203	0209026	CERAMIC (RESISTOR SHAPE) 0.01MF+-30%	RT701	5007477	SEMI VARIABLE 10K OHM
C204	0209027	CERAMIC (RESISTOR SHAPE) 0.01MF+-30%	RV102-104	5008761	PRE-SET VOLUME
C207	0209026	CERAMIC (RESISTOR SHAPE) 0.01MF+-30%	RV401	5000921	VARIABLE RESISTOR 10K OHM (B)
C210	0209026	CERAMIC (RESISTOR SHAPE) 0.01MF+-30%	RV402	5000922	VARIABLE RESISTOR 100K OHM (C)
C308LR	0209025	CERAMIC (RESISTOR SHAPE) 6800PF+-30%	RV403	5000923	VARIABLE RESISTOR 100K OHM (B)
C352-355	0209010	CERAMIC (RESISTOR SHAPE) 1000PF+-10%	RV404	5000931	VARIABLE RESISTOR 50K OHM (B)
C356	0209026	CERAMIC (RESISTOR SHAPE) 0.01MF+-30%	RV406LR	5000932	VARIABLE RESISTOR 50K OHM (B)
C357	0209010	CERAMIC (RESISTOR SHAPE) 1000PF+-10%	R448	0171028	OXIDE METAL FILM 39 OHM+-5% 1W
C358	0256370	TANTALUM ELECTROLYTIC 0.1MF 35V	R541LR	0171017	OXIDE METAL FILM 120 OHM+-5% 1W
C359	0209026	CERAMIC (RESISTOR SHAPE) 0.01MF+-30%	R543	0171011	METAL FILM 0.22 OHM+-10% 2W
C360	0256381	TANTALUM ELECTROLYTIC 3.3MF 16V	R601	0170463	CARBON FILM 560 OHM+-5% 1/2W
C361	0256381	TANTALUM ELECTROLYTIC 3.3MF 16V	SEMI-CONDUCTORS		
C362-365	0209026	CERAMIC (RESISTOR SHAPE) 0.01MF+-30%	D1G1	5330571	DIODE 1S2473VE
C366	0209026	CERAMIC (RESISTOR SHAPE) 0.01MF+-30%	D1Q2-104	5330771	DIODE SILICON 1SV55
C368	0256381	TANTALUM ELECTROLYTIC 3.3MF 16V			
C369	0209026	CERAMIC (RESISTOR SHAPE) 0.01MF+-30%			

TRK-9900E,E(BS)

SYMBOL-NO	P-NO	DESCRIPTION	SYMBOL-NO	P-NO	DESCRIPTION
D106	5330573	DIODE 1S2473	IC408	5350611	IC UPC574J
D107	5330571	DIODE 1S2473VE	IC501	5353391	IC STK430
D108	5331621	DIODE 1N60FM	IC701	5352381	IC HA12024
D109	5330661	DIODE SILICON 1S2790	IC702	5359501	IC MPD4011C
D110	5330571	DIODE 1S2473VE	LED601	5380241	LED GL 3PR1 [E(BS)]
D111	5330571	DIODE 1S2473VE	LED701	5380521	LED LA4010A
D151-154	5330573	DIODE 1S2473	LED801	5380621	LED SLC-22UR
D351	5330573	DIODE 1S2473	LED802	5380622	LED SLC22GG5
D352	5330573	DIODE 1S2473	LED803	5380621	LED SLC-22UR
D353-356	5330573	DIODE 1S2473	Q101	5322151	TRANSISTOR 3SK60
D358-360	5330573	DIODE 1S2473	Q102-104	5321281	TRANSISTOR SILICON 2SC1675-L
D361	5330848	ZENER DIODE R05.1E82	Q151	5321271	TRANSISTOR SILICON 2SC1674L
D362	5330573	DIODE 1S2473	Q152-155	5321281	TRANSISTOR SILICON 2SC1675-L
D401LR	5330573	DIODE 1S2473	Q156-158	5321252	TRANSISTOR 2SA844D
D402LR	5330573	DIODE 1S2473	Q201	5321281	TRANSISTOR SILICON 2SC1675-L
D403LR	5330573	DIODE 1S2473	Q203	5322621	TRANSISTOR 2SC2320E
D404-406	5330573	DIODE 1S2473	Q204	5321293	TRANSISTOR 2SC1740LN-R
D408-413	5330573	DIODE 1S2473	Q205	5322621	TRANSISTOR 2SC2320E
D414LR	5330573	DIODE 1S2473	Q206	5321252	TRANSISTOR 2SA844D
D415LR	5331501	DIODE 1K34A	Q207	5321293	TRANSISTOR 2SC1740LN-R
D416LR	5330573	DIODE 1S2473	Q351	5322911	TRANSISTOR 2SC2063P
D417	5330574	DIODE 1S2473 [E(BS)]	Q352-355	5322992	TRANSISTOR 2SA937R
D501	5330573	DIODE 1S2473	Q356	5322992	TRANSISTOR 2SA937R
D502LR	5330131	DIODE 1S2076	Q401LR	5321293	TRANSISTOR 2SC1740LN-R
D601	5330831	DIODE 55VB10	Q402LR	5320813	TRANSISTOR 2SC945P
D602	5331452	DIODE SRP02-100NLF	Q403LR	5320813	TRANSISTOR 2SC945P
D603	5331451	DIODE SRP02	Q404LR	5321293	TRANSISTOR 2SC1740LN-R
D604	5330501	DIODE SILICON UO-5B	Q405LR	5320813	TRANSISTOR 2SC945P
D611	5330574	DIODE 1S2473 [E(BS)]	Q406LR	5321293	TRANSISTOR 2SC1740LN-R
D701	5330573	DIODE 1S2473	Q407LR	5321662	TRANSISTOR 2SC2021S
D702	5330573	DIODE 1S2473	Q408	5322621	TRANSISTOR 2SC2320E
D801	5330001	DIODE SILICON VO3C	Q409	5322621	TRANSISTOR 2SC2320E
D802	5330573	DIODE 1S2473	Q410	5320813	TRANSISTOR 2SC945P
D803	5330001	DIODE SILICON VO3C	Q412	5320813	TRANSISTOR 2SC945P
D804	5330001	DIODE SILICON VO3C	Q413LR	5322621	TRANSISTOR 2SC2320E
IC201	5351691	IC HA12413	Q414LR	5321293	TRANSISTOR 2SC1740LN-R
IC301	5350683	IC HA11227	Q415LR	5321293	TRANSISTOR 2SC1740LN-R
IC302	5365491	IC HD14066B	Q501	5320433	TRANSISTOR 2SC1061C
IC351	5365861	IC MSL2312RS	Q503	5322213	TRANSISTOR 2SC1741R
IC352	5352541	IC TA78L006P	Q504LR	5322621	TRANSISTOR 2SC2320E
IC401LR	5350961	IC BA340	Q505LR	5322621	TRANSISTOR 2SC2320E
IC402	5357002	IC TA1024A	Q506	5322213	TRANSISTOR 2SC1741R
IC403	5356832	MODULE TA3003D	Q507	5322621	TRANSISTOR 2SC2320E
IC404	5352791	IC TA7324P	Q601	5320433	TRANSISTOR 2SC1061C
IC405LR	5350962	IC BA340	Q701	5322213	TRANSISTOR 2SC1741R
IC407	5350713	IC BA328-LN			

SYMBOL-NO	P-NO	DESCRIPTION	SYMBOL-NO	P-NO	DESCRIPTION
Z0401	5330482	ZENER DIODE SILICON AW01-7	J402	5651141	5P DIN SOCKET
Z0501	5330531	ZENER DIODE SILICON HZ-12A	J405LR	5673331	JACK-3.5MMD (EXT.MIC)
Z0502	5330313	ZENER DIODE SILICON HZ7C	J501	5674261	HEADPHONE JACK
Z0503	5331012	ZENER DIODE HZ5B	J502LR	5676331	PIN JACK (EXT.SPEAKER)
Z0601	5330533	ZENER DIODE SILICON HZ-12C	△J601	5653242	POWER SOCKET
Z0701	5330392	ZENER DIODE SILICON HZ6B	MD351	5310611	LCD MODULE
TRANSFORMERS			PTH501	0249791	POSISTOR BE101
T101	5140071	FM IF	RL1	5641441	RELAY
T151	5160101	AM IF	S 1	5605132	SLIDE SWITCH (BAND)
T201	5130122	AM IF	S351-355	5633352	PUSH SWITCH (SLEEP, HOUR, MINUTE, MINUTE RESET, CLOCK/TIMER ADJ.)
T202	5140024	FM IF	S356	5634421	PUSH SWITCH (CLOCK/TIMER/FREQ. /PRESET/MANUAL TUNING/APC)
COILS			S401	5623611	SLIDE SWITCH (REC./P.B.)
L101	5126912	FM RF COIL	S402	5605191	SLIDE SWITCH (FUNCTION)
L102	5126912	FM RF COIL	S403	5605171	SLIDE SWITCH (TAPE SELECTOR)
L103	5126391	FM TRAP COIL	S404	5634411	PUSH SWITCH (LOUDNESS)
L104	5126312	FM OSCILLATOR COIL	S405	5633622	PUSH SWITCH (REC MUTE)
L105	5126391	FM TRAP COIL	S406	5633621	PUSH SWITCH (MODE)
L106	5123271	FM TRAP COIL 0.5MH	S407	5633621	PUSH SWITCH (DOLBY NR)
L151	5123493	SW ANTENNA COIL	S408	5633621	PUSH SWITCH (FM MUTE)
L152	5113504	FERRITE CORE ANTENNA	S409	5624281	SLIDE SWITCH (RIF)
L153	5113504	FERRITE CORE ANTENNA	S410	5634166	PUSH SWITCH (REC MODE)
L154	5123494	SW OSC COIL	S501	5604211	LEVER SWITCH (POWER)
L155	5120319	MW OSC COIL	S502	5634411	PUSH SWITCH (LIGHT)
L156	5120465	LW OSC COIL	S601	5633315	PUSH SWITCH (FF/REW)
L301LR	5101731	LCR FILTER	S701	5633352	PUSH SWITCH (PROGRAM)
L351	5152091	CHOKO 180MICRO H	FOR ACCESSORIES		
L401	5260861	OSCILLATOR BLOCK	△	5747321	POWER CORD (E)
L402	5260811	DC-DC CONVERTER	△	5746341	POWER CORD [E(BS)]
L403LR	5260215	TRAP COIL 33MH		5896391	FM ANTENNA [E(BS)]
L404LR	5120274	CHOKO COIL	FOR CASSETTE DECK ASSEMBLY (B)		
L406LR	5150571	CHOKO COIL 33MH	1	6767661	CHASSIS ASSEMBLY
L407	5150575	CHOKO COIL 1000UM	2	6374061	MICRO WHEEL
L502	5152123	CHOKO 18MICRO H	3	6346351	PULLEY
L503	5152129	CHOKO COIL 47MICRO H	4	6316231	SPRING M
MISCELLANEOUS			5	6767941	LED HOLDER ASSEMBLY
	5659121	BACK COVER	6	6570291	MIC COVER
CF201	5160302	CERAMIC FILTER 10.7MHZ	7	6301951	SPRING
CF202	5160302	CERAMIC FILTER 10.7MHZ	8	8699410	BT BIND HEAD SCREW-3MMDX10MM(BLACK)
△F501	5720179	FUSE 1A	9	5310581	LED MODULF
△F601	5720177	FUSE 2A	10	5421641	BUILT IN MICROPHONE
△F602	5721062	FUSE 4A 250V	11	5605182	ROTARY SWITCH (BAND,FUNCTION)
△F603	5721063	FUSE 1.25A			
J401L,R	5676321	2P PIN JACK (PHONO)			

SYMBOL-NO	P-NO	DESCRIPTION	SYMBOL-NO	P-NO	DESCRIPTION
12	5605161	SWITCH WIRE	54	6768341	DAMPER
13	5605154	SWITCH WIRE	55	8745406	BINDING SCREW - 3MM X 6MM
14	5605211	LEVER SWITCH (TAPE)	56	6766231	FUNCTION BUTTON ASSEMBLY
15	5605201	SWITCH WIRE	57	6093262	CASSETTE LID ASSEMBLY
16	7338492	RECORD SPRING ASSEMBLY	58	6766242	CONTROL LID ASSEMBLY
17	6535071	RECORD SPRING	59	6106022	REAR CASE ASSEMBLY (E)
18	5559263	COUNTER		6106023	REAR CASE ASSEMBLY [E(BS)]
19	6354106	BELT	60	7450911	TERMINAL PIECE
20	6546652	SPRING	61	5687142	CAP TERMINAL
21	6766191	RESET BUTTON ASSEMBLY	62	6324112	SPRING
22	8691110	BT BIND SCREW-2MMDX10MM	63	7450344	BATTERY TERMINAL
23	8691312	BT BIND SCREW-2.6MMDX12MM	64	7450343	BATTERY TERMINAL
24	8671404	DT BIND SCREW-3MMDX4MM	65	6303973	SPRING
25	8691306	SCREW (BT,6X6)	66	6303972	SPRING
26	5633361	PUSH SWITCH (PAUSE)	67	6303483	SPRING
27	5633361	PUSH SWITCH (PLAY)	68	7451162	BATTERY TERMINAL
28	5603302	LEAF SWITCH (START)	69	6173663	BATTERY LID ASSEMBLY
29	5632412	LEAF SWITCH (POWER)	70	6766931	FUSE COVER
30	5641091	REED RELAY	71	6746902	SWITCH COVER [E(BS)]
31	6764551	LED HOLDER	72	6768451	COVER(A) [E(BS)]
MISCELLANEOUS			73	6768461	COVER(B) [E(BS)]
32	6283661	KNOB (BAND,FUNCTION)	74	8711735	PAN HEAD SCREW-5MMDX35MM
33	6283651	KNOB (VOLUME)	75	8744414	BIND SCREW-3MMDX14MM
34	6283641	KNOB (BALANCE,TREBLE,BASS)	△76	5212983	POWER TRANSFORMER (E)
35	6291231	PUSH BUTTON(LOUDNESS,LIGHT,REC MODE)		5212984	POWER TRANSFORMER [E(BS)]
36	6291161	LEVER KNOB (POWER,TAPE)	77	5752511	ROD ANTENNA
37	6283454	KNOB (REC LEVEL)	78	5671661	FM ANTENNA TERMINAL
38	6291241	KNOB (RIF)	△79	5602022	SEESAW SWITCH (AC POWER) [E(BS)]
39	6283781	KNOB (TUNING)	80	6769381	SPEAKER BOX ASSEMBLY(R)
40	6291661	KNOB ASSEMBLY	81	6769362	BAFFLE PLATE ASSEMBLY
41	8745406	BINDING SCREW - 3MM X 6MM	82	7342961	JOINT HOLDER ASSEMBLY (UPPER)
42	8698414	BT SCREW-3MMDX14MM	83	7342962	JOINT HOLDER ASSEMBLY (UNDER SIDE-R)
43	6106042	FRONT CASE ASSEMBLY (E)	84	6173673	CORD COVER (R)
	6106043	FRONT CASE ASSEMBLY [E(BS)]	85	6751682	STOPPER
44	6291201	PUSH BUTTON	86	5406741	SPEAKER-12CM
45	6291261	PUSH BUTTON (DRPS)	87	5401641	SPEAKER-5CM
46	6291221	PUSH BUTTON (TIMER/CLOCK)	88	5747461	SPEAKER CORD
47	6291681	PUSH BUTTON(SLEEP, HOUR, MIN, MIN. RESET)	89	6769371	SPEAKER BOX ASSEMBLY(L)
48	7338531	PUSH BUTTON ASSEMBLY (FM MUTE, REC MUTE, MODE, DOLBY NR)	90	7342963	JOINT HOLDER ASSEMBLY (UNDER SIDE-L)
49	7776171	TERMINAL PLATE(LARGE)	91	6173674	CORD COVER (L)
50	7776181	TERMINAL PLATE (SMALL)	92	7781148	BT SCREW-3MM X 50 MM
51	7544965	JOINT SHAFT			
52	6334431	HANDLE ASSEMBLY			
53	7338561	EJECT BUTTON ASSEMBLY			

EXPLODED VIEW (Cabinet)

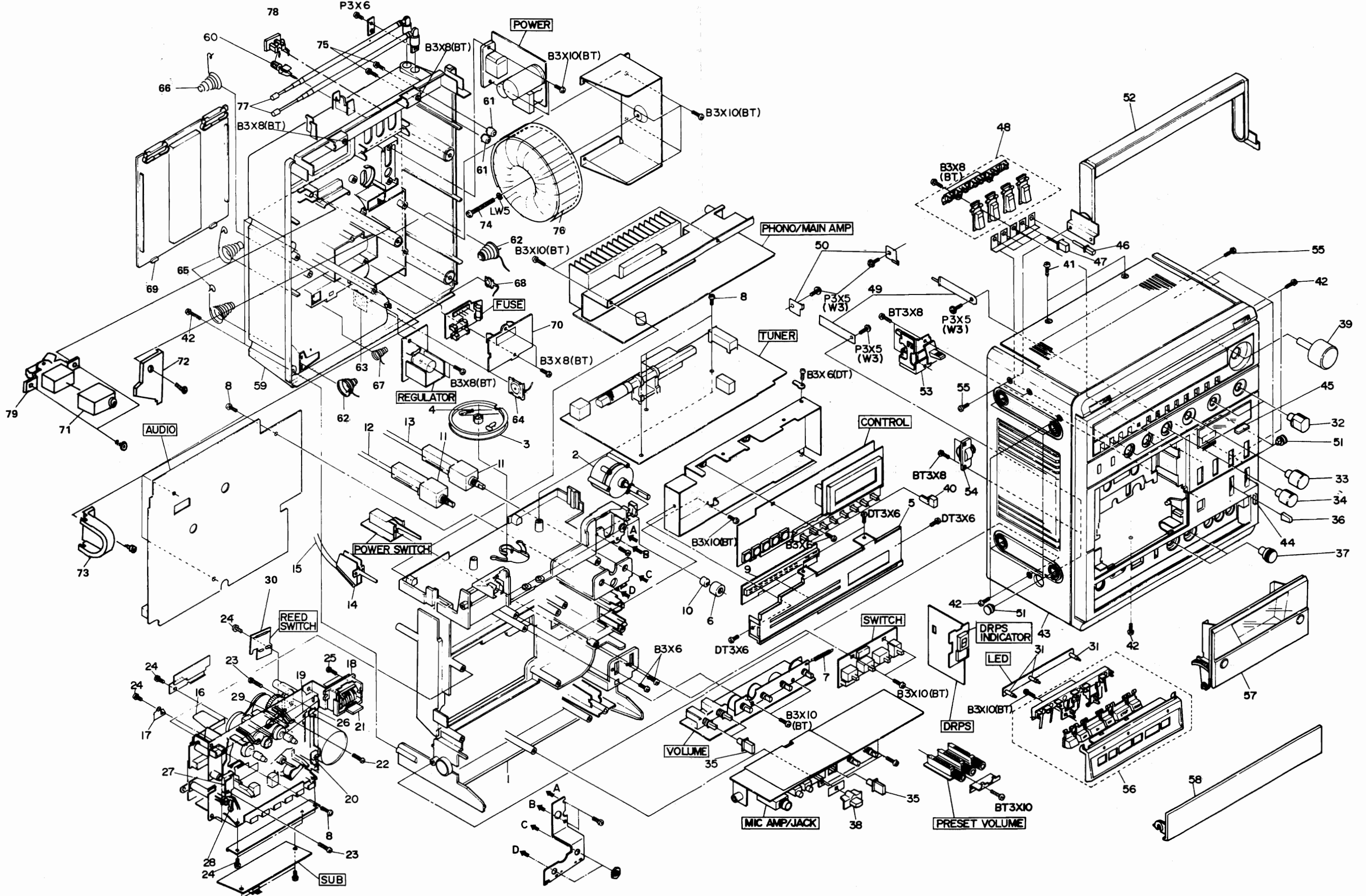

Note: Components marked without numbers in this drawing are not specified as replacement parts.

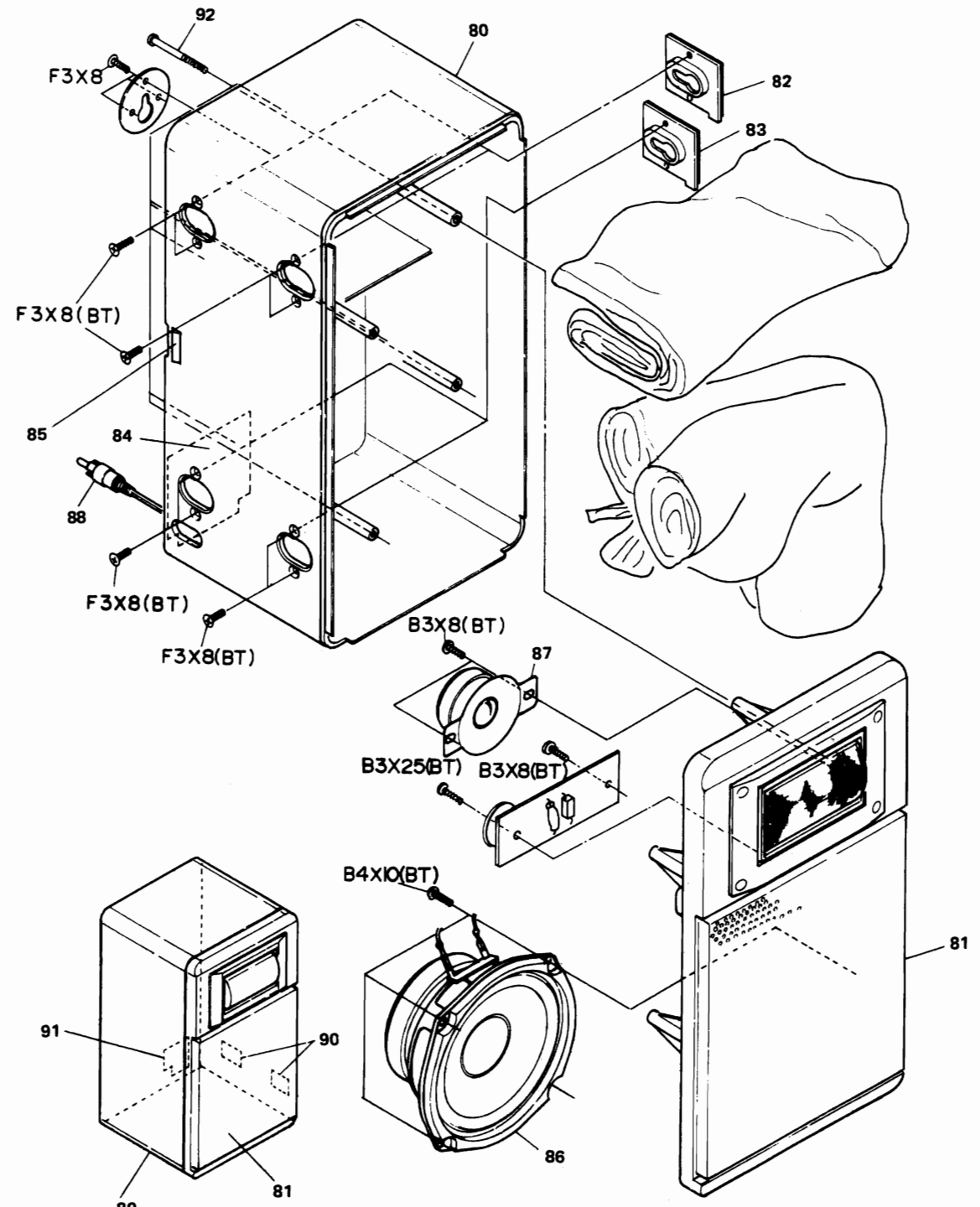
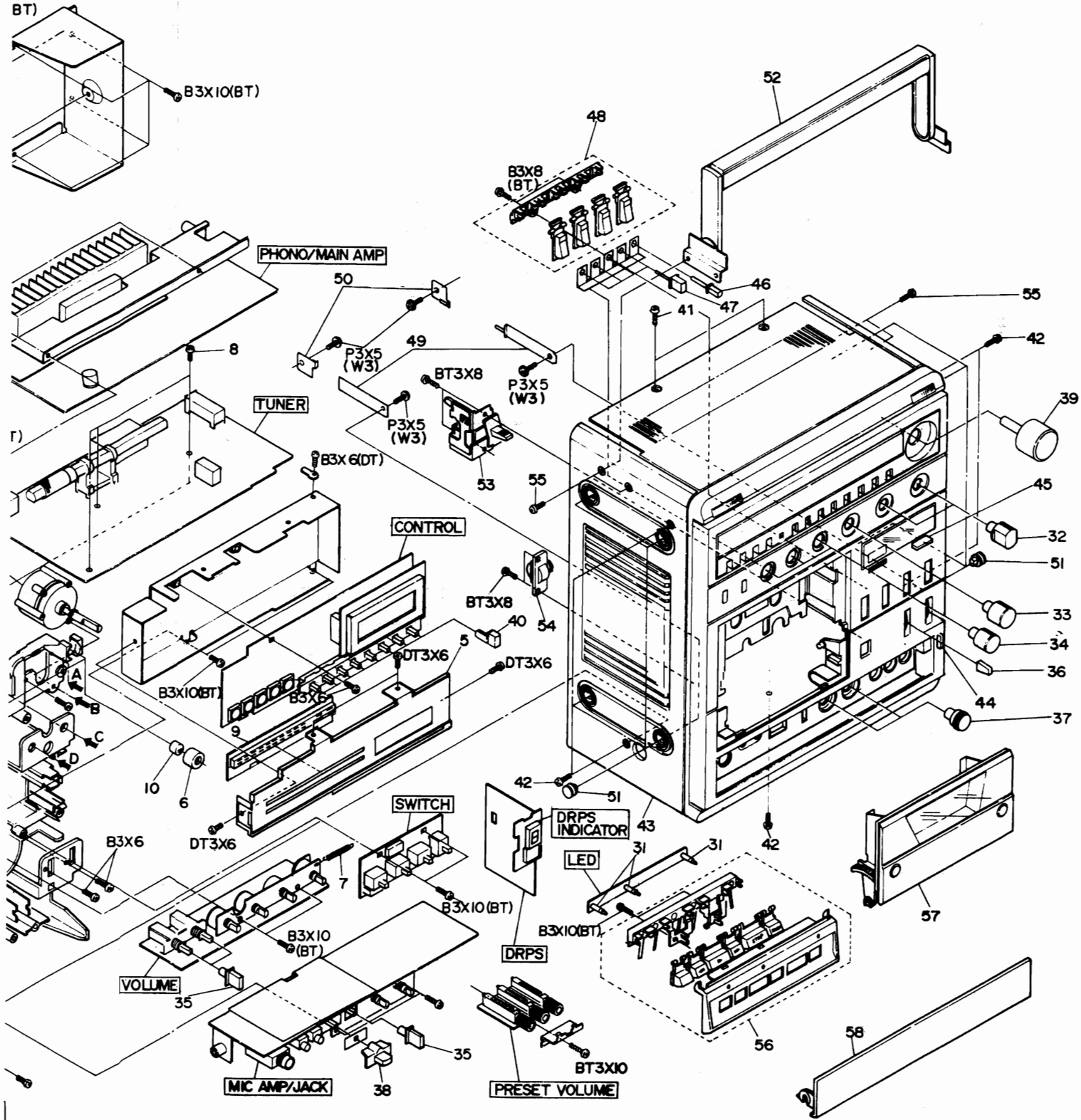

Type of head	
P Pan head screw	BT Binding head tapping screw
F Flat countersunk head screw	BL Bolt
B Binding head screw	W Washer
T Round head tapping screw	E "E" ring
Length (L mm)	
Diameter (D mm)	

When ordering hardware excluding stated on these lists, be sure to make your orders with type and size.

parts.

SCHMATIC DIAGRAM (Tuner Section)

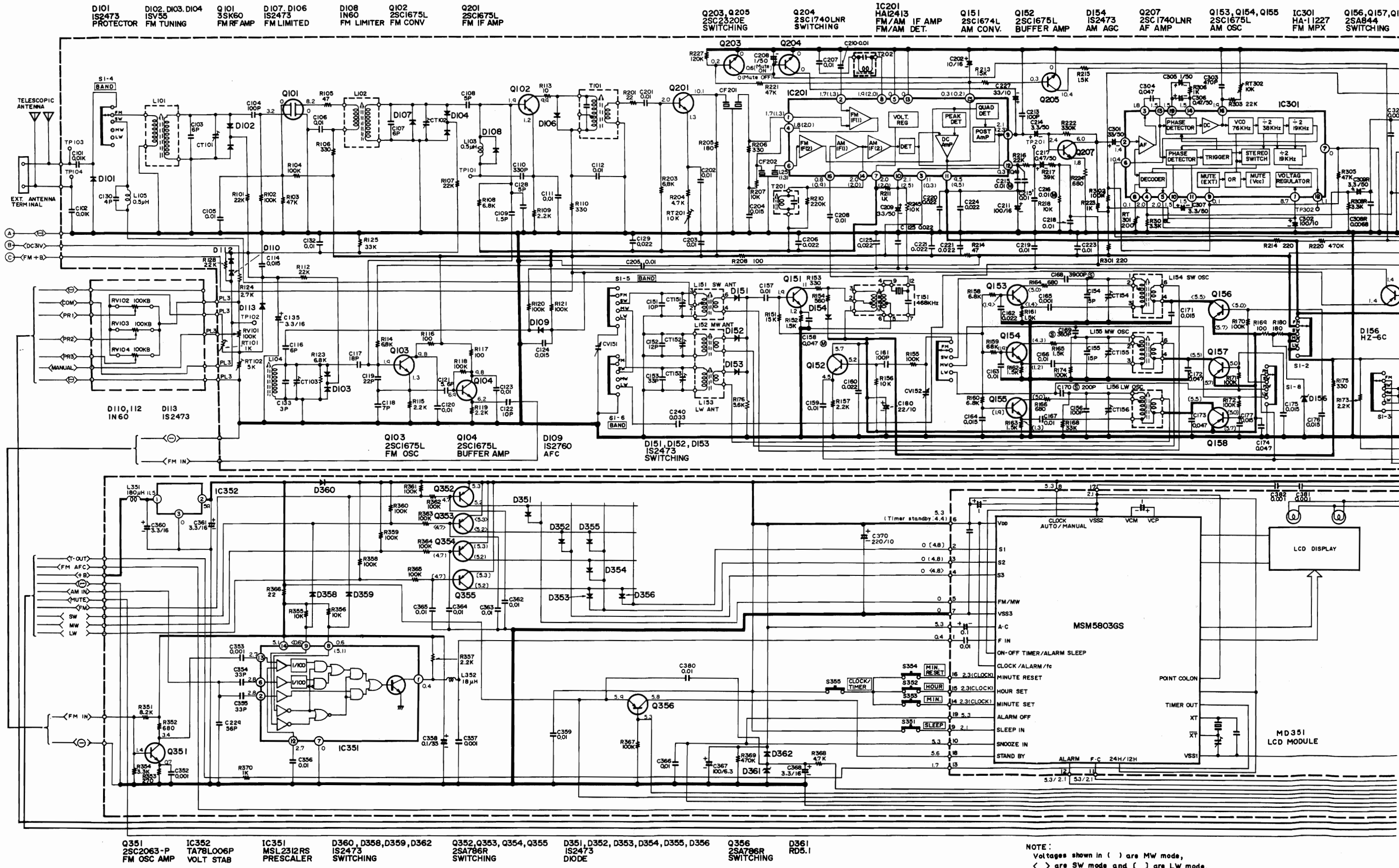

- Q101** IS2473 PROTECTOR
Q102 IS2473 FM LIMITED
Q103 2SC1675L FM OSC
Q104 2SC1675L BUFFER AMP
Q105 2SC1675L FM CONV
Q109 IS2760 AFC
Q151 2SC1674L AM CONV.
Q152 2SC1675L BUFFER AMP
Q153 2SC1675L AM OSC
Q154 IS2473 AM AGC
Q155 2SC1675L AM OSC
Q156 2SA844 SWITCHING
Q157 2SA844 SWITCHING
Q158 2SA844 SWITCHING
Q201 2SC1675L FM IF AMP
Q203 2SC2320E SWITCHING
Q204 2SC1740LNR SWITCHING
IC201 HA12413 FM/AM IF AMP FM/AM DET.
IC301 HA-11227 FM MPX
IC351 MSL2312RS PRESCALER
IC352 TA78L06P VOLT STAB
IC355 MS5803GS
MD351 LCD MODULE
D101 IS2473 PROTECTOR
D102 ISV55 FM TUNING
D103 IS2473 FM LIMITED
D104 IS2473 FM LIMITED
D105 IS2473 FM LIMITED
D106 IS2473 FM LIMITED
D107 IS2473 FM LIMITED
D108 IS2473 FM LIMITED
D109 IS2760 AFC
D151 IS2473 SWITCHING
D152 IS2473 SWITCHING
D153 IS2473 SWITCHING
D351 IS2473 DIODE
D352 IS2473 DIODE
D353 IS2473 DIODE
D354 IS2473 DIODE
D355 IS2473 DIODE
D356 IS2473 DIODE
D360 D358, D359, D362 SWITCHING
D361 IS2473 DIODE
Q351 2SC2063-P FM OSC AMP
Q352 MSL2312RS PRESCALER
Q353 MSL2312RS PRESCALER
Q354 MSL2312RS PRESCALER
Q355 MSL2312RS PRESCALER
Q356 2SA786R SWITCHING
D362 IS2473 DIODE

NOTE:
 Voltages shown in () are MW mode,
 < > are SW mode and [] are LW mode.

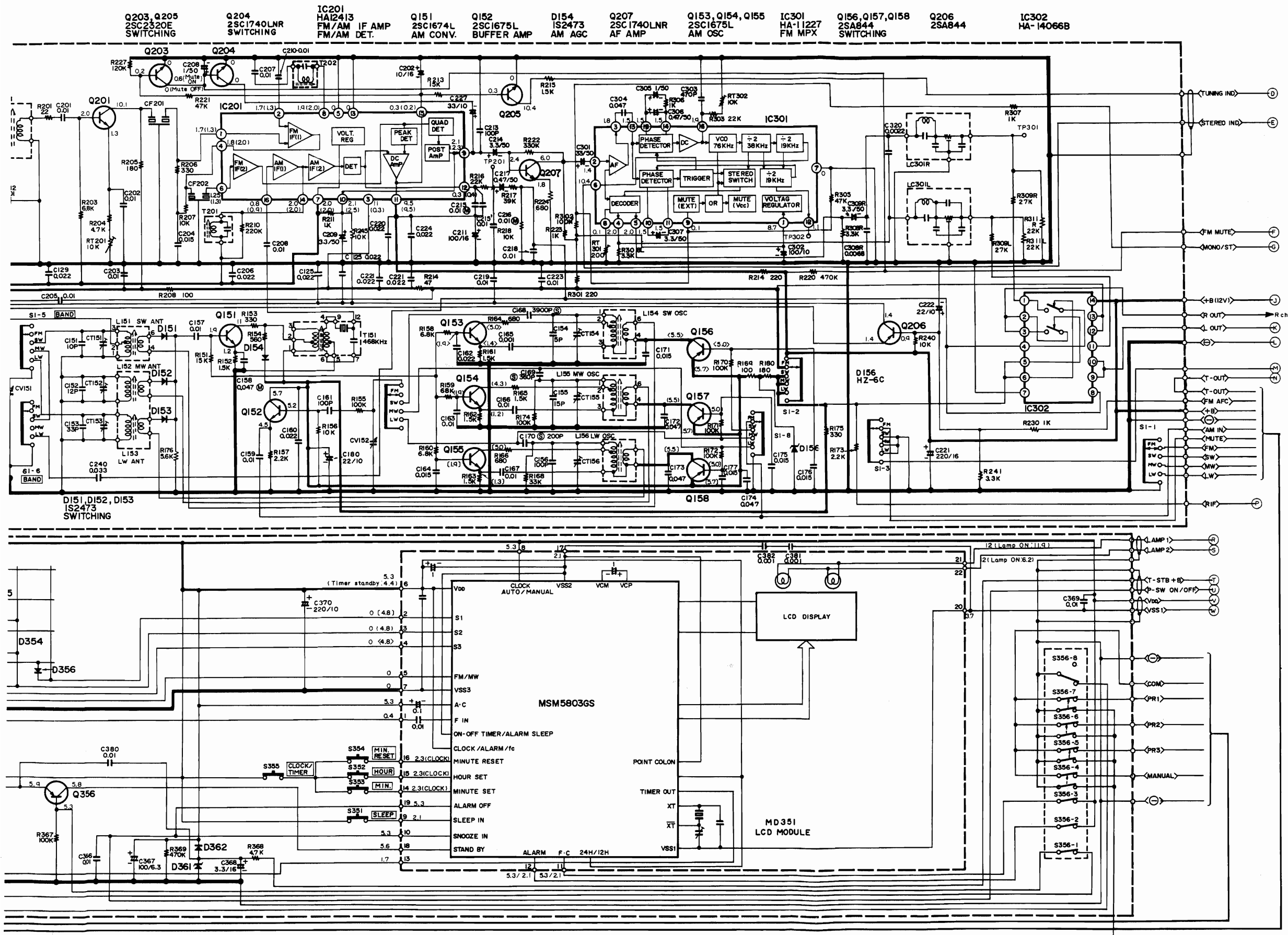

Note

1. Voltage measured at base of chassis with minimum volume control and no signal.
2. Nomenclature of Resistors and Capacitors.

Circuit No.	
Value	No indicated Ω(Ohm) M : 1000 kΩ
Tolerance	No indicated ±5% K : ±10% M : ±20%
Wattage	No indicated ¼W
Sort	No indicated Carbon film RC : Composition RW : Wire wound RS : Oxide metal film RN : Fixed metal film

Circuit No.	
Value	No indicated μF P : PF
Tolerance	No indicated ±10% J : ± 5% M : ±20% Z : +80% - 20% D : ±0.5pF C : ±0.25pF
Sort	Ceramic Electrolytic Mylar Polyester Styrol
Voltage	No indicated 50VW

3. Be sure to make your orders of resistors and capacitors with value, voltage, tolerance and sort.
4. When replacing capacitors marked with *, use specified ones stated on parts list since required temperature characteristics.

D352, D353, D354, D355, D356

Q356
2SA786R
SWITCHING

D361
RD5.1

NOTE:
Voltages shown in () are MW mode,
< > are SW mode and [] are LW mode.

CIRCUIT BOARD DIAGRAM

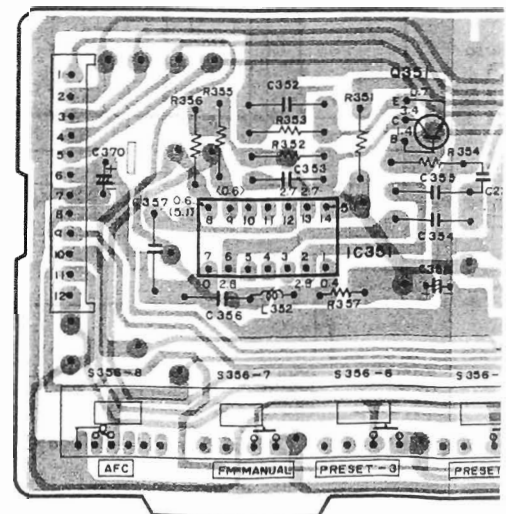
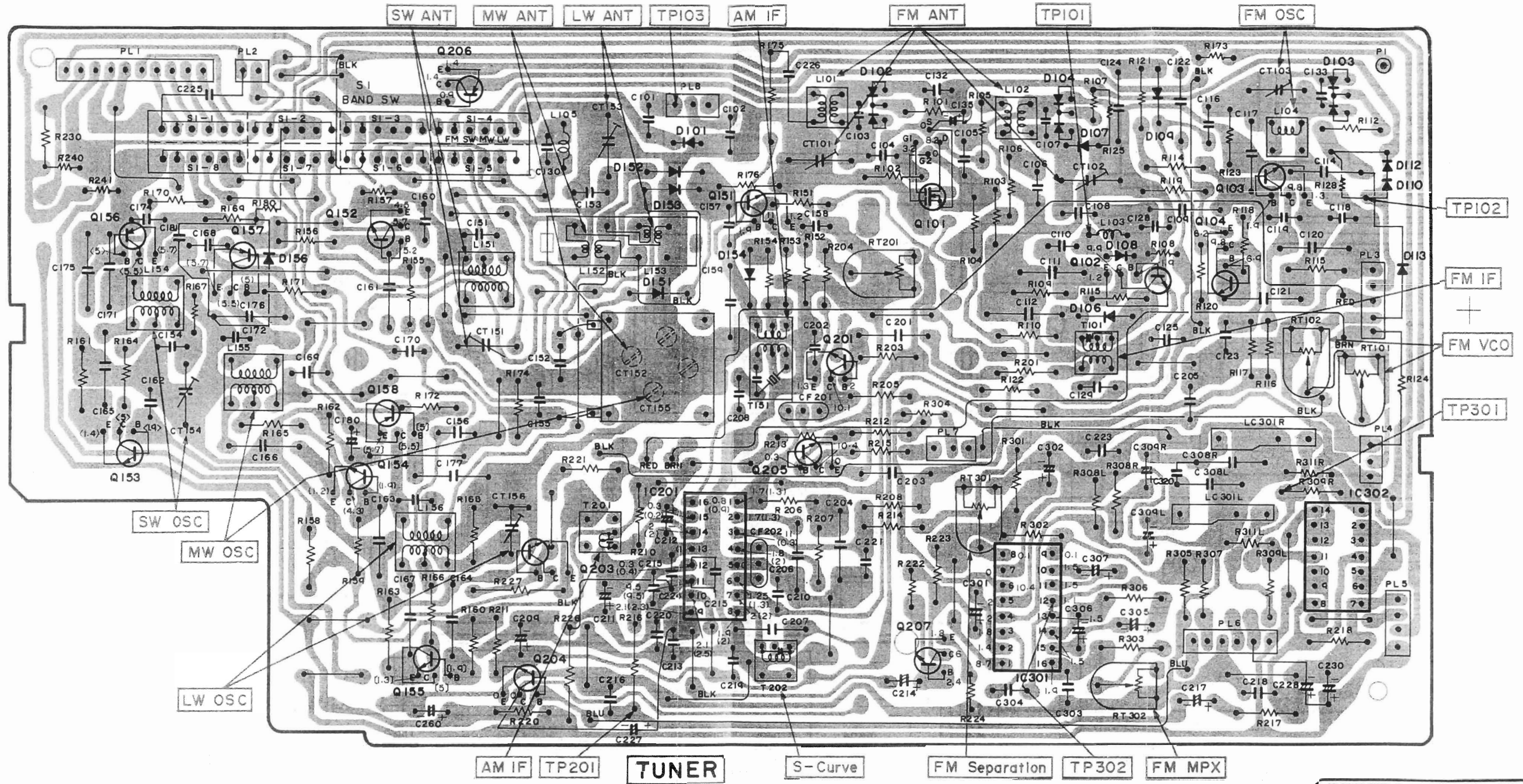

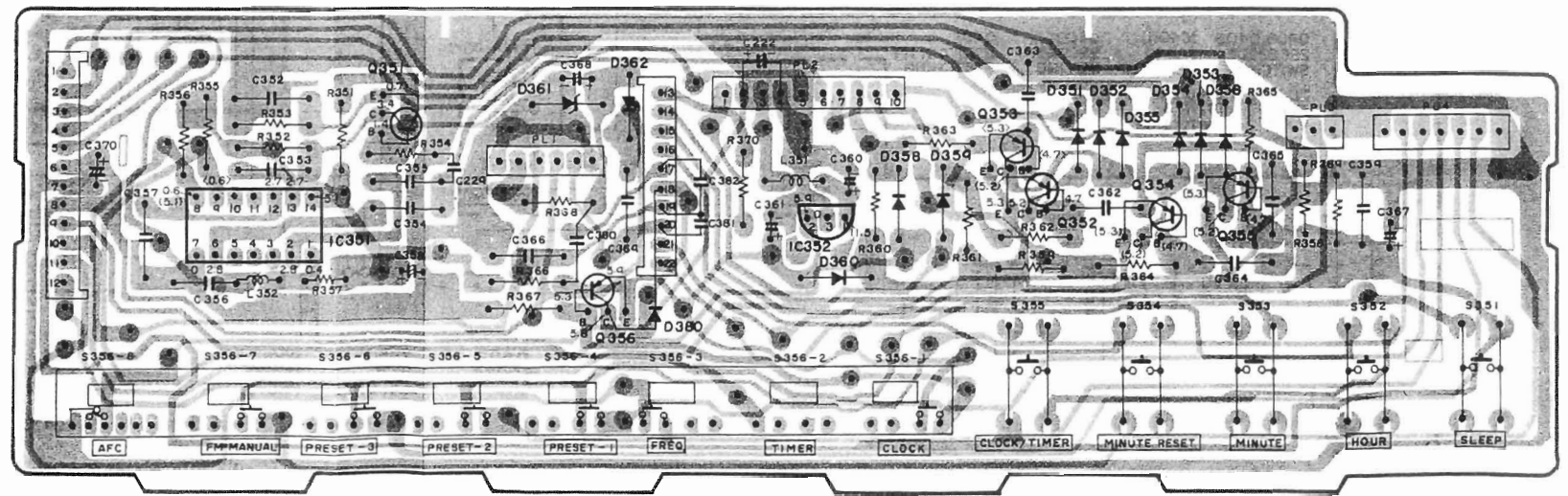
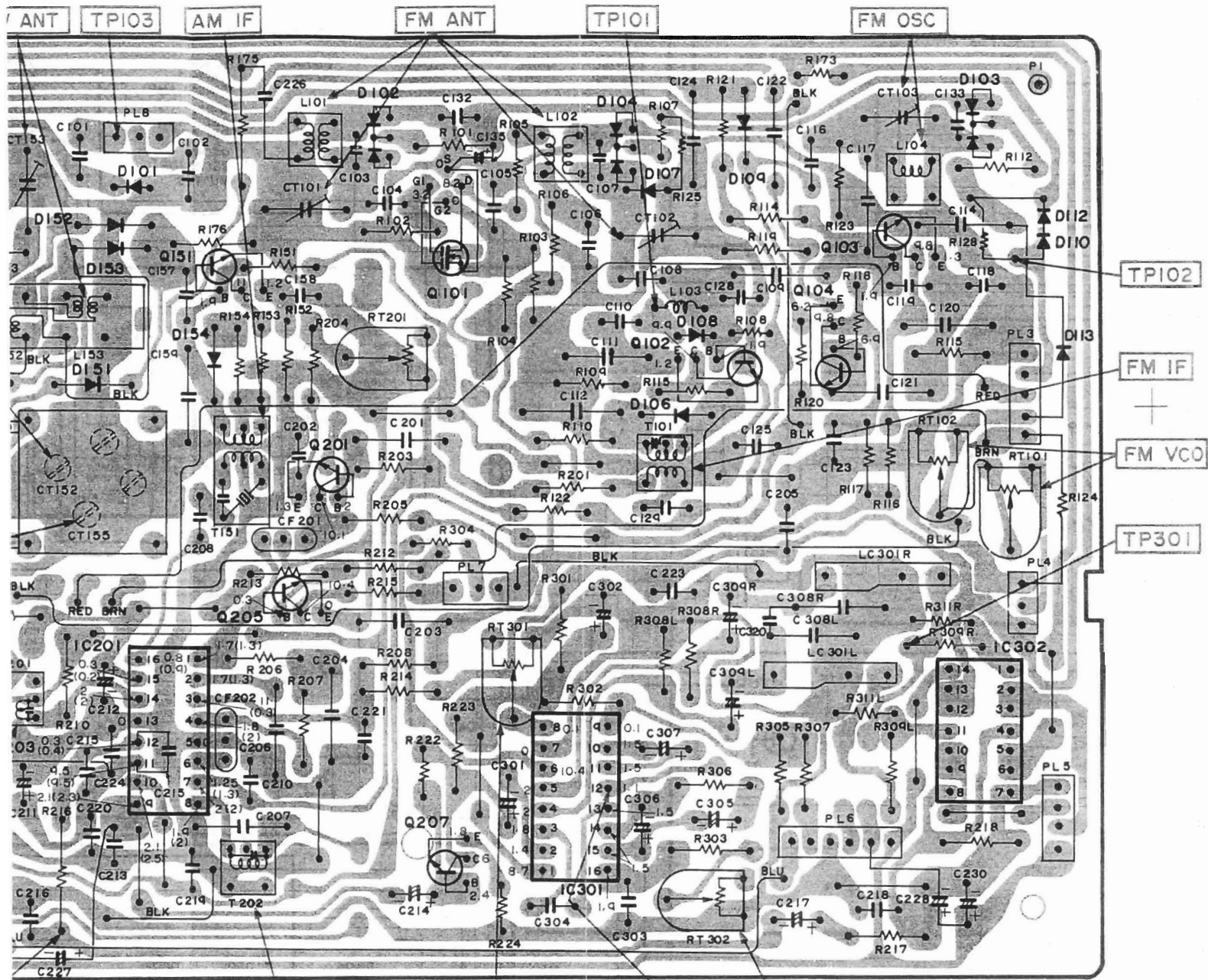

CONTROL

SCHEMATIC DIAGRAM (Tape/Audio Sectio)

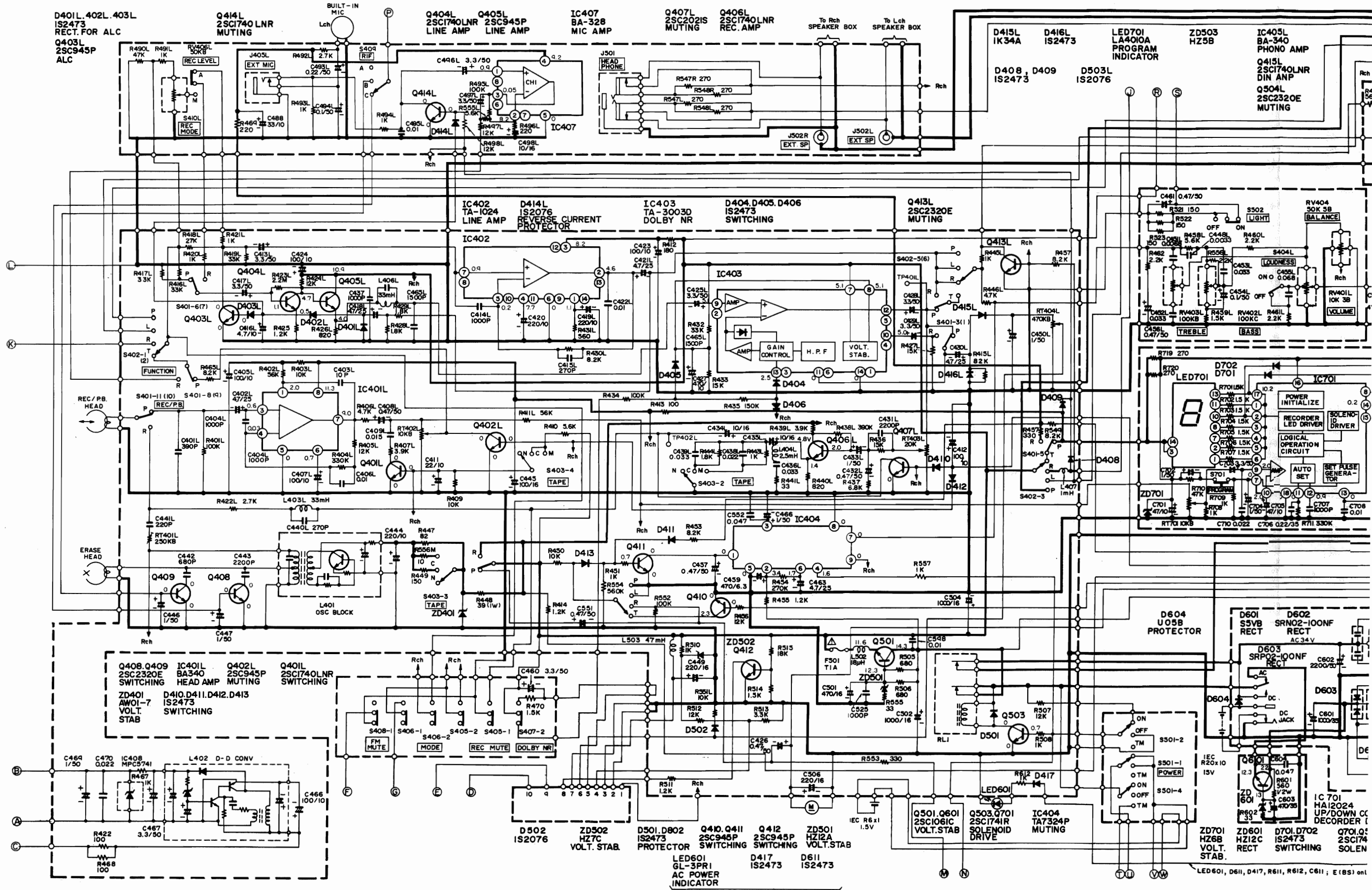

For E (BS) only

TRK-9900E,E(BS) TRK-9900E,E(BS)

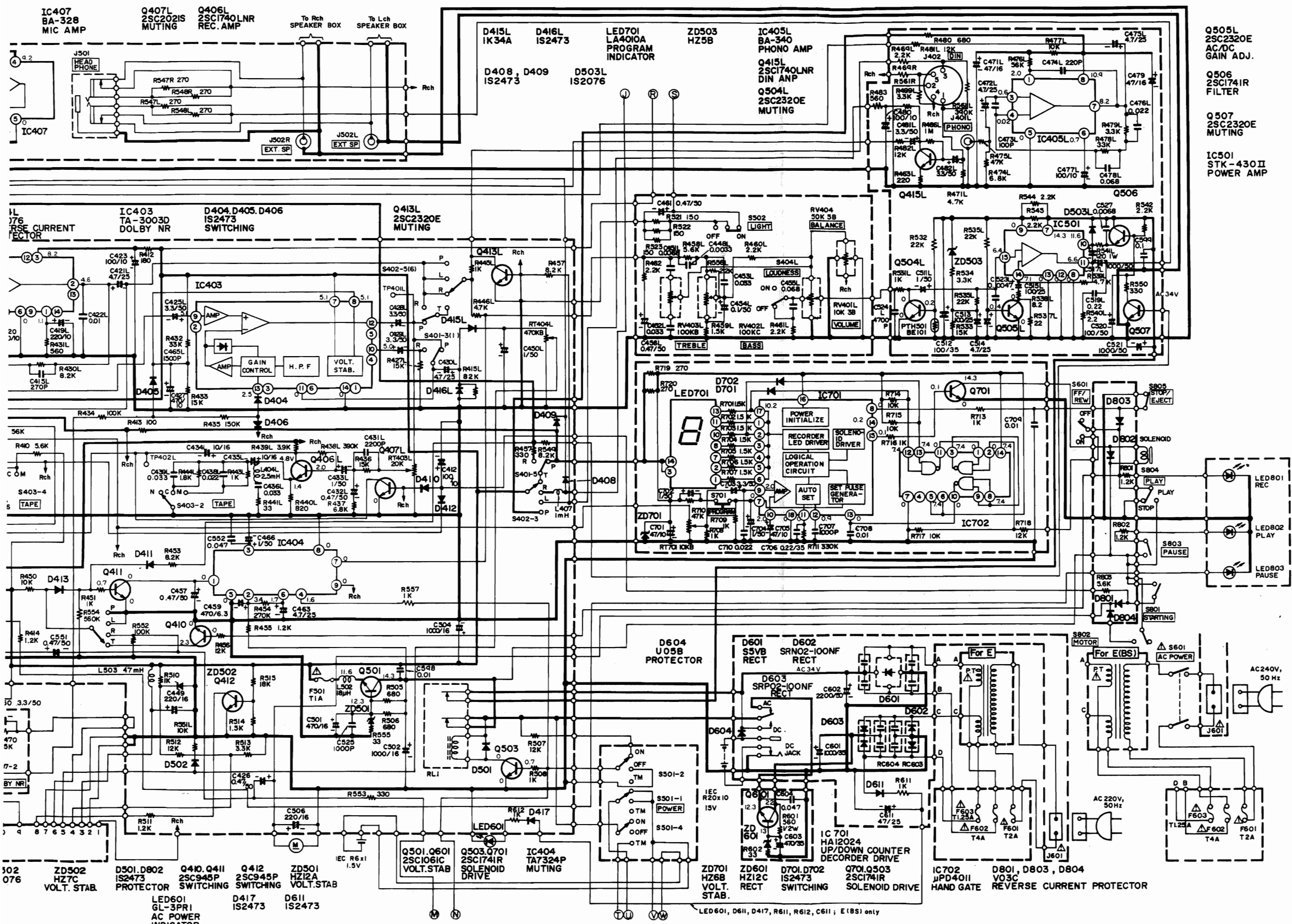

- Q505L
2SC2320E
AC/DC
GAIN ADJ.
- Q506
2SC1741R
FILTER
- Q507
2SC2320E
MUTING
- IC501
STK-430II
POWER AMP

- 102 076 ZD502 HZ7C VOLT. STAB.
- D501, D802 IS2473 PROTECTOR
- Q410, Q411 2SC945P SWITCHING
- Q412 2SC945P SWITCHING
- ZD501 HZ12A VOLT. STAB.
- LED601 GL-3PRI AC POWER INDICATOR
- D417 IS2473
- D611 IS2473
- ZD701 HZ68 VOLT. STAB.
- ZD601 HZ12C VOLT. STAB.
- D701, D702 IS2473 SWITCHING
- Q701, Q503 2SC1741R SOLENOID DRIVE
- IC702 µPD4011 HAND GATE
- D801, D803, D804 V03C REVERSE CURRENT PROTECTOR

CIRCUIT BOARD DIAGRAM

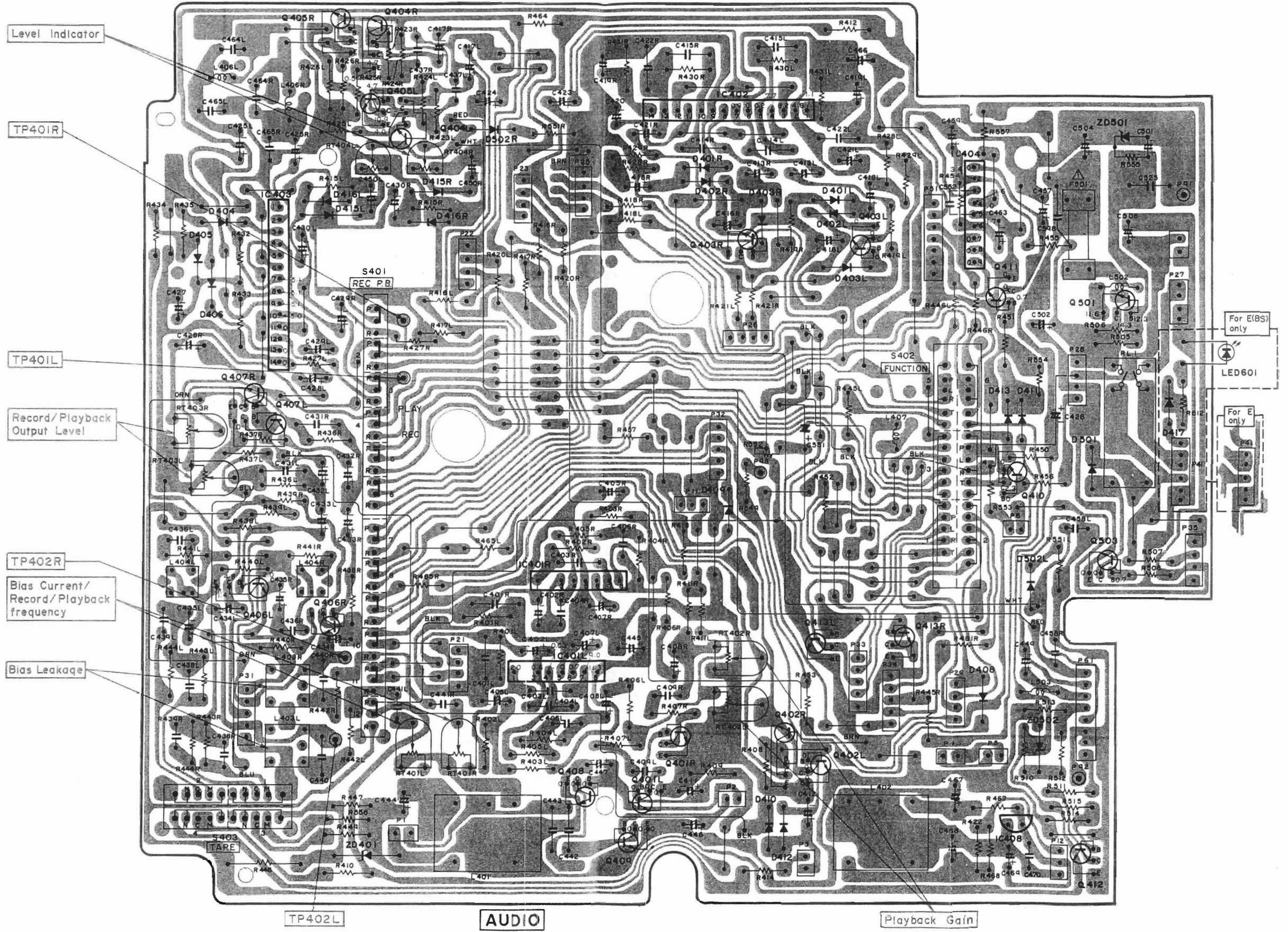

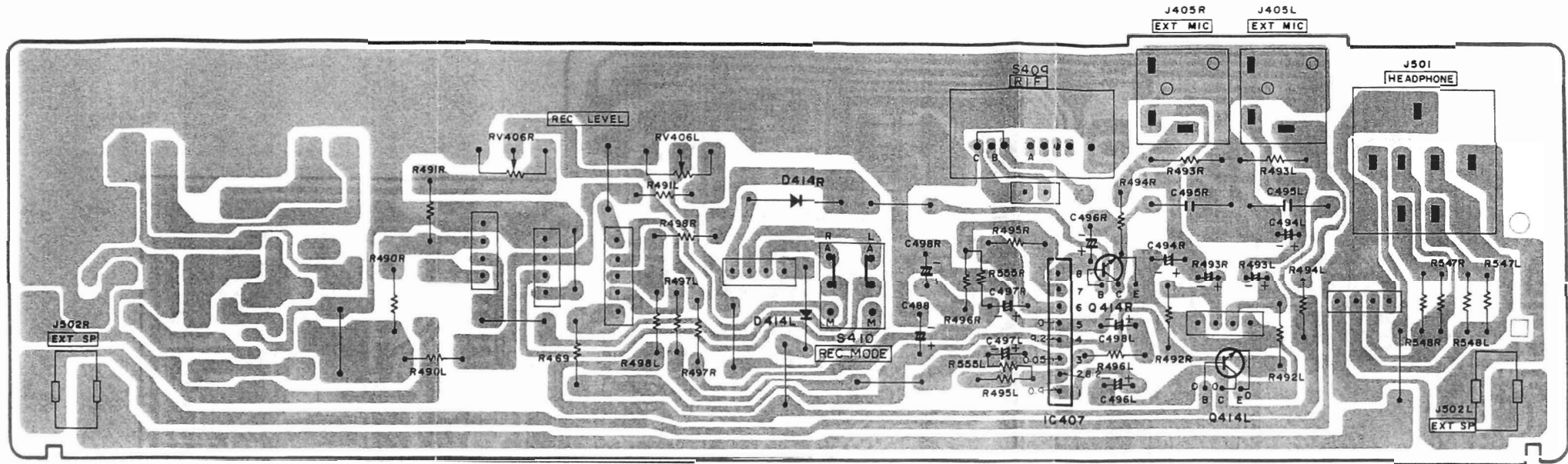

MIC AMP/JACK

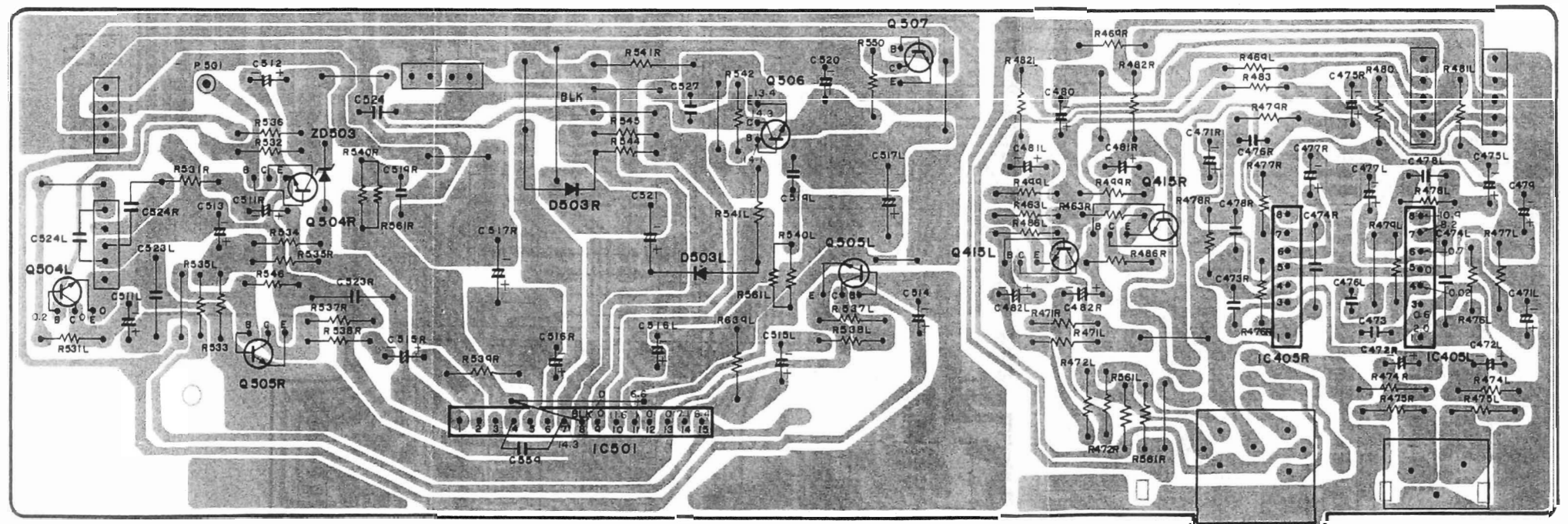

PHONO/MAIN AMP

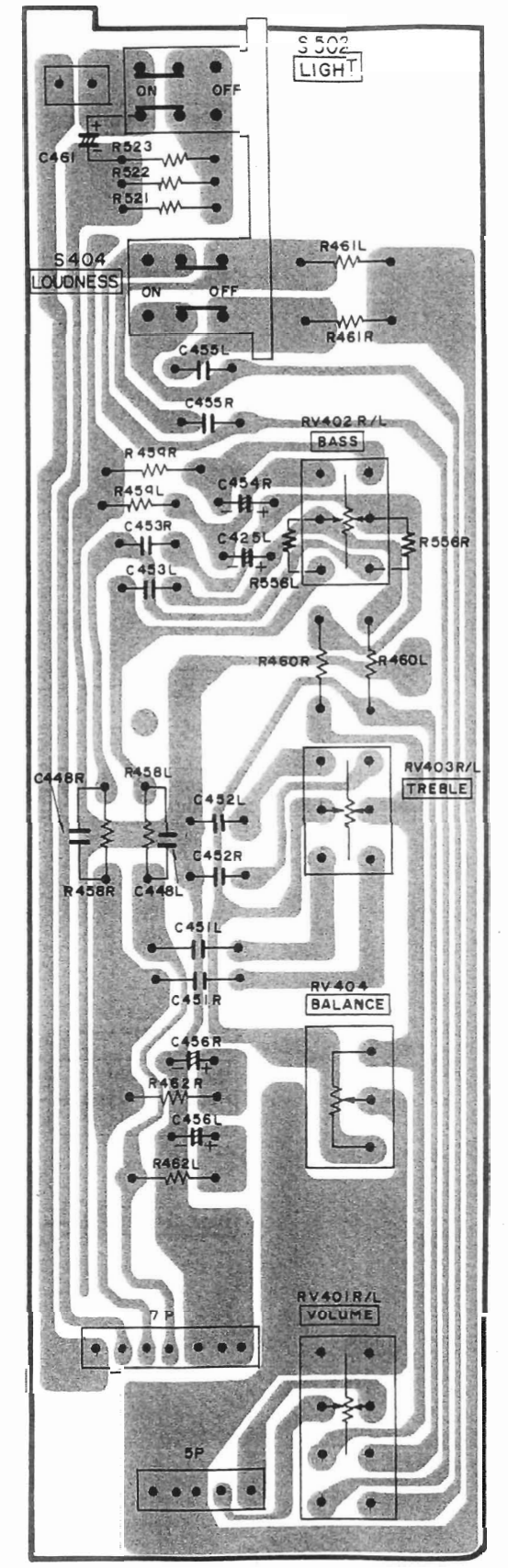

VOLUME

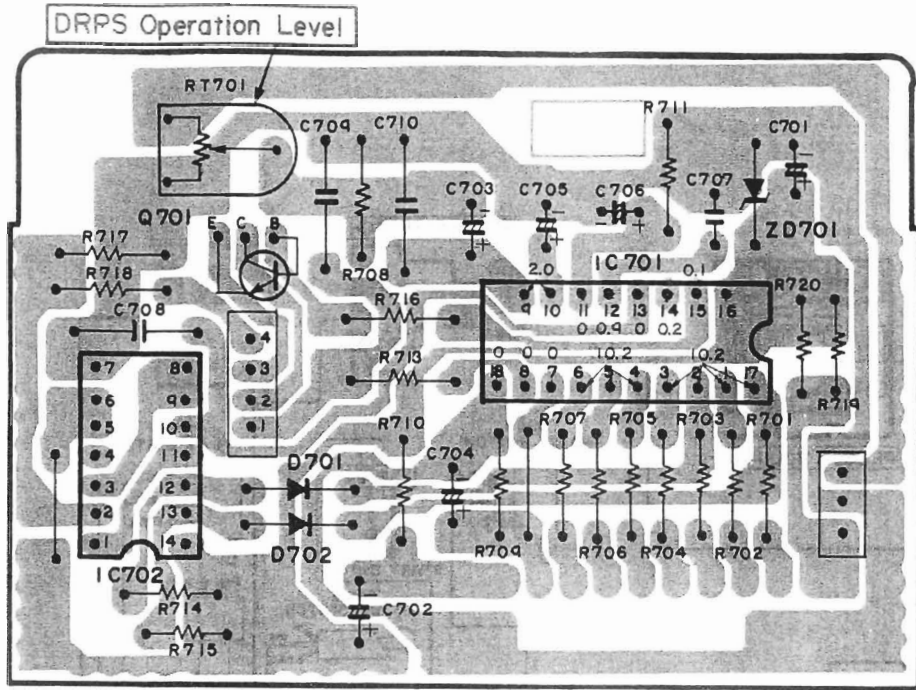

DRPS

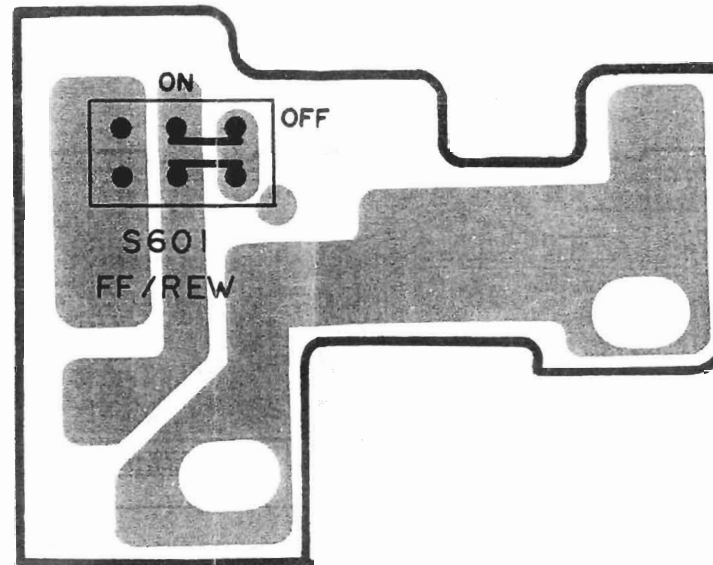

FF/REW SWITCH



LED

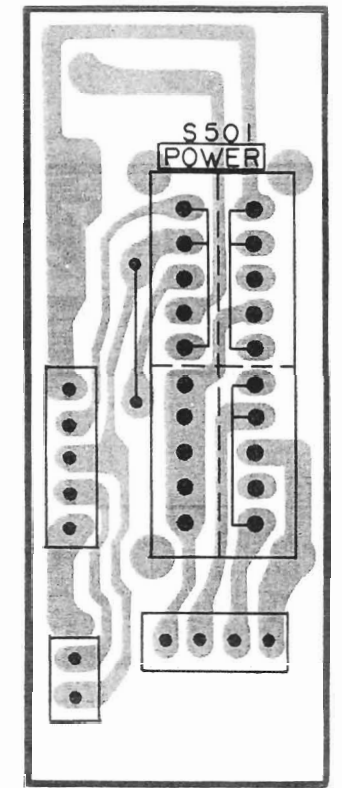

POWER SWITCH

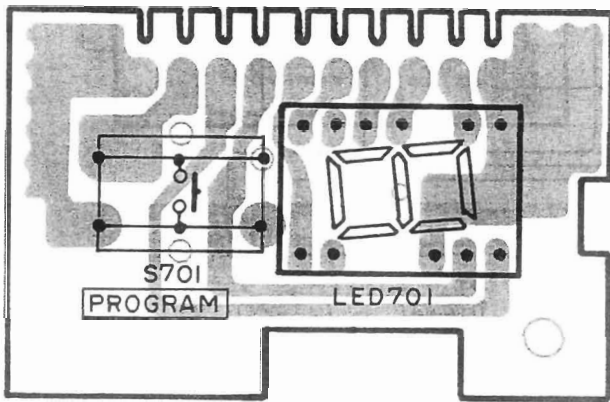

DRPS INDICATOR

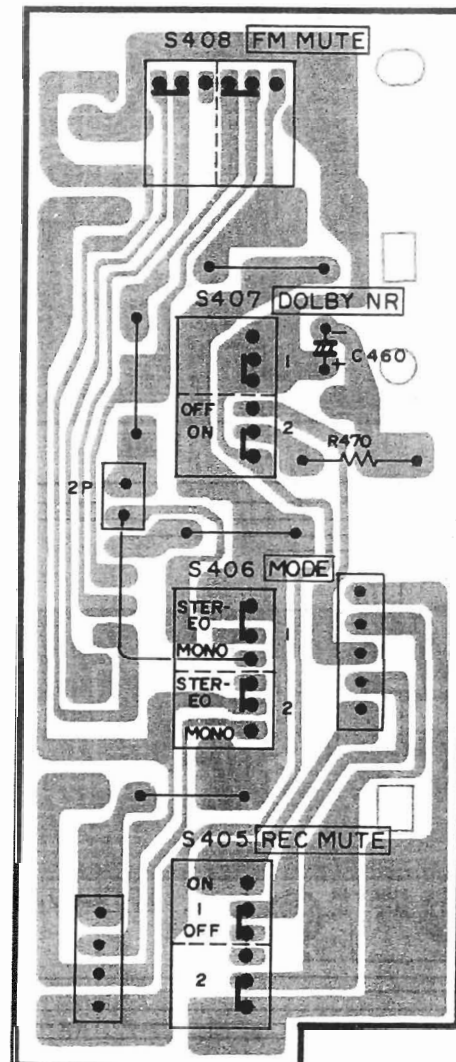

SWITCH

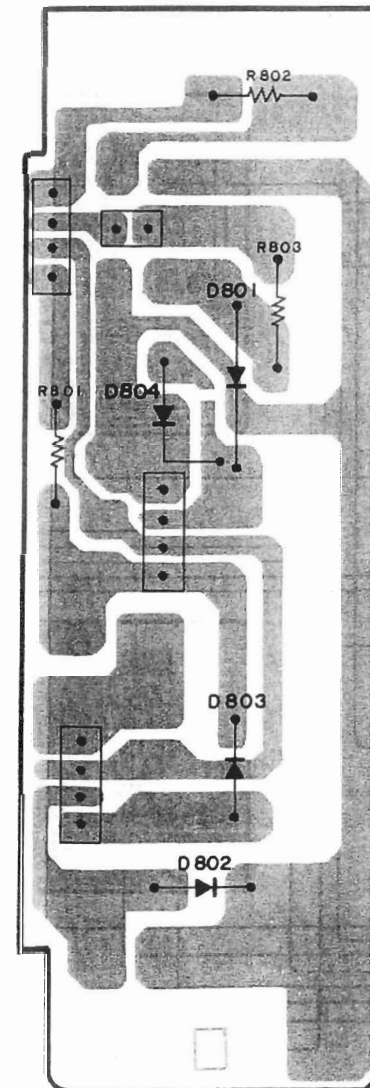

SUB

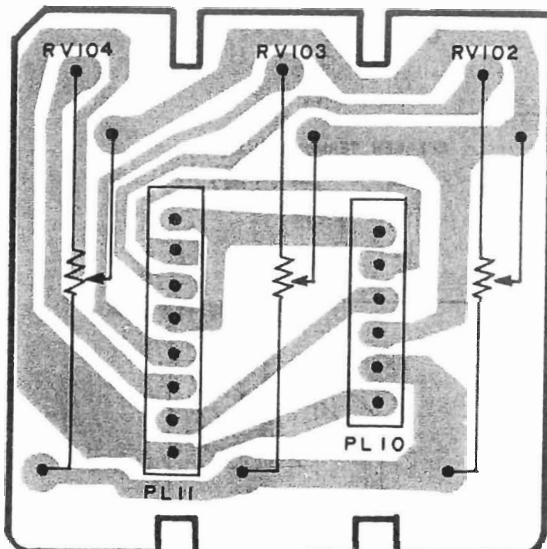

PRESET VOLUME

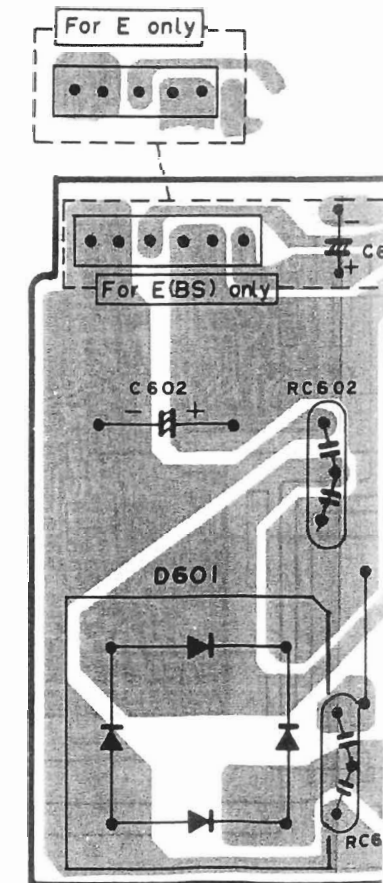

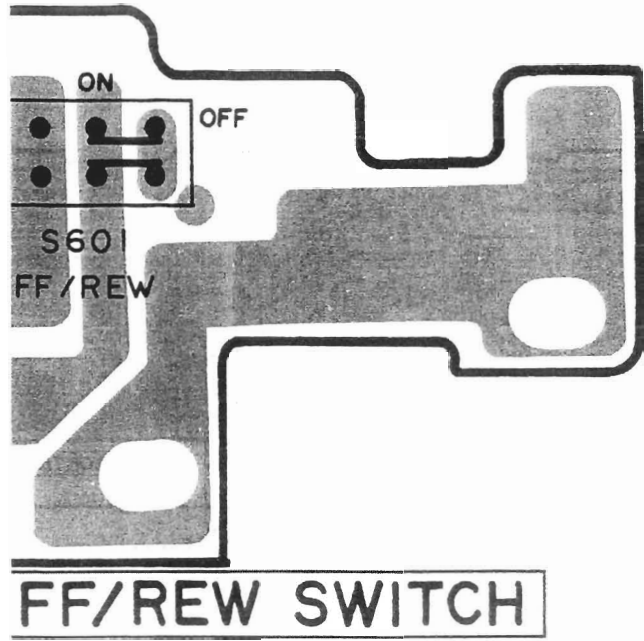

FF/REW SWITCH

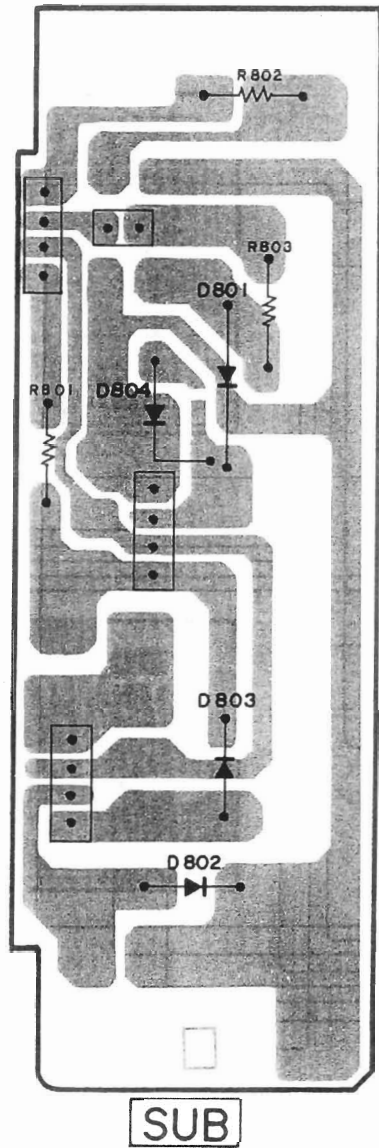

SUB

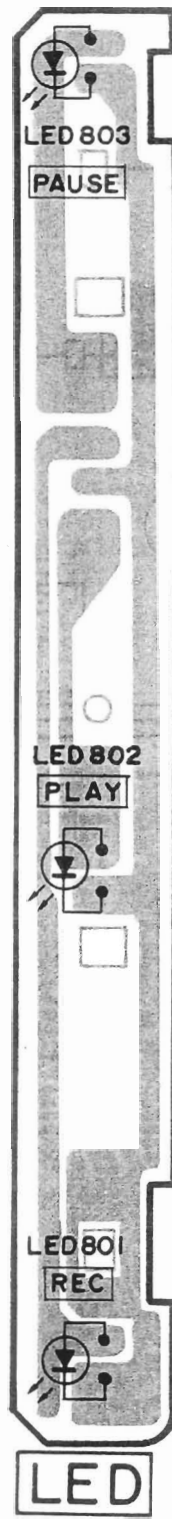

LED

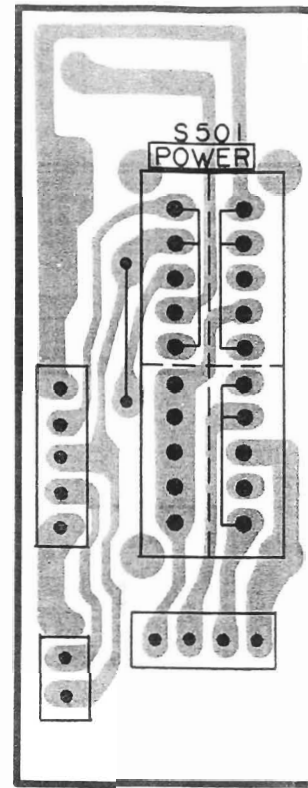

POWER SWITCH

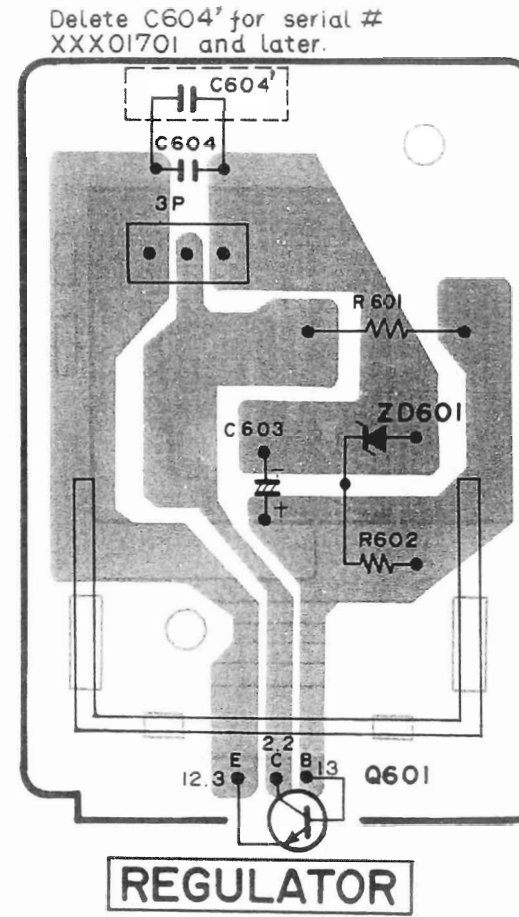

REGULATOR

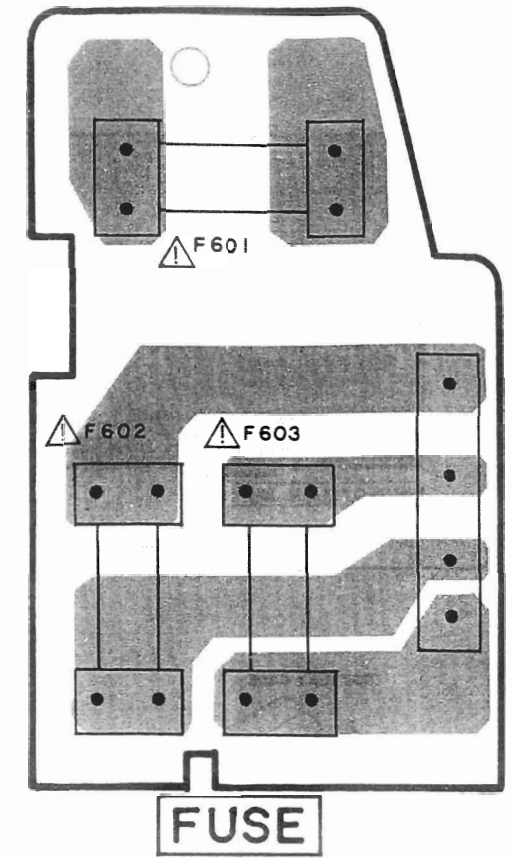

FUSE

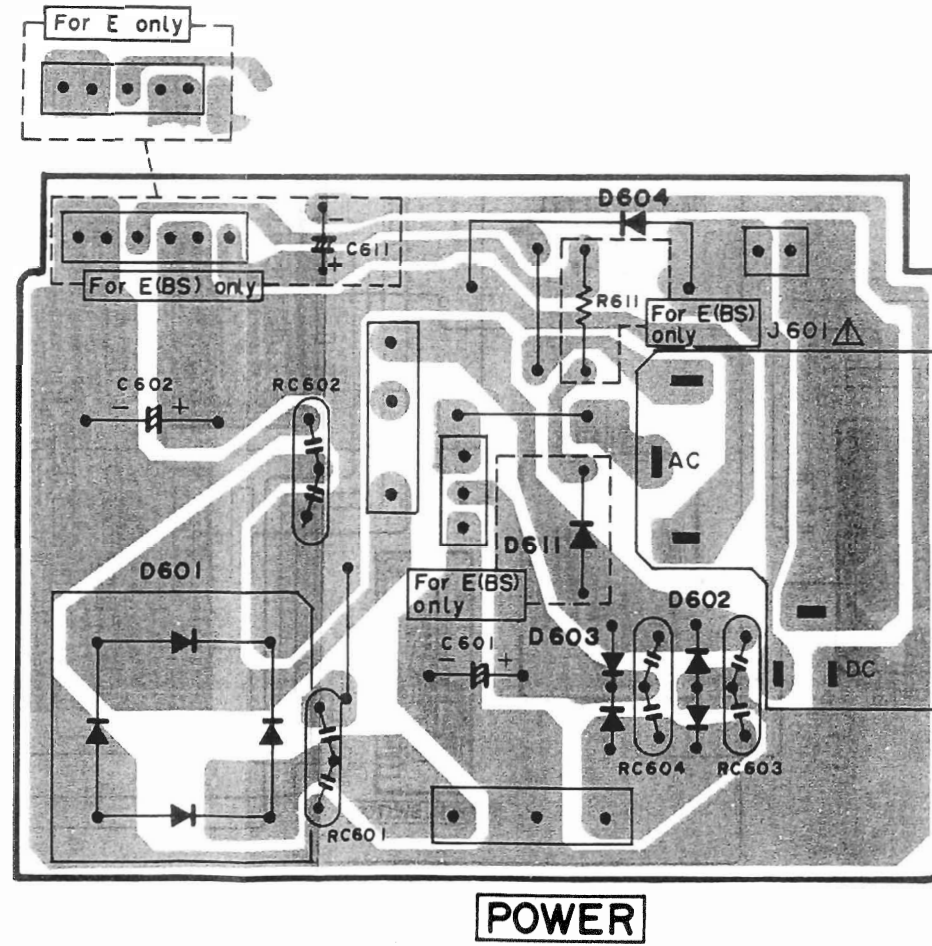

POWER

WIRING DIAGRAM

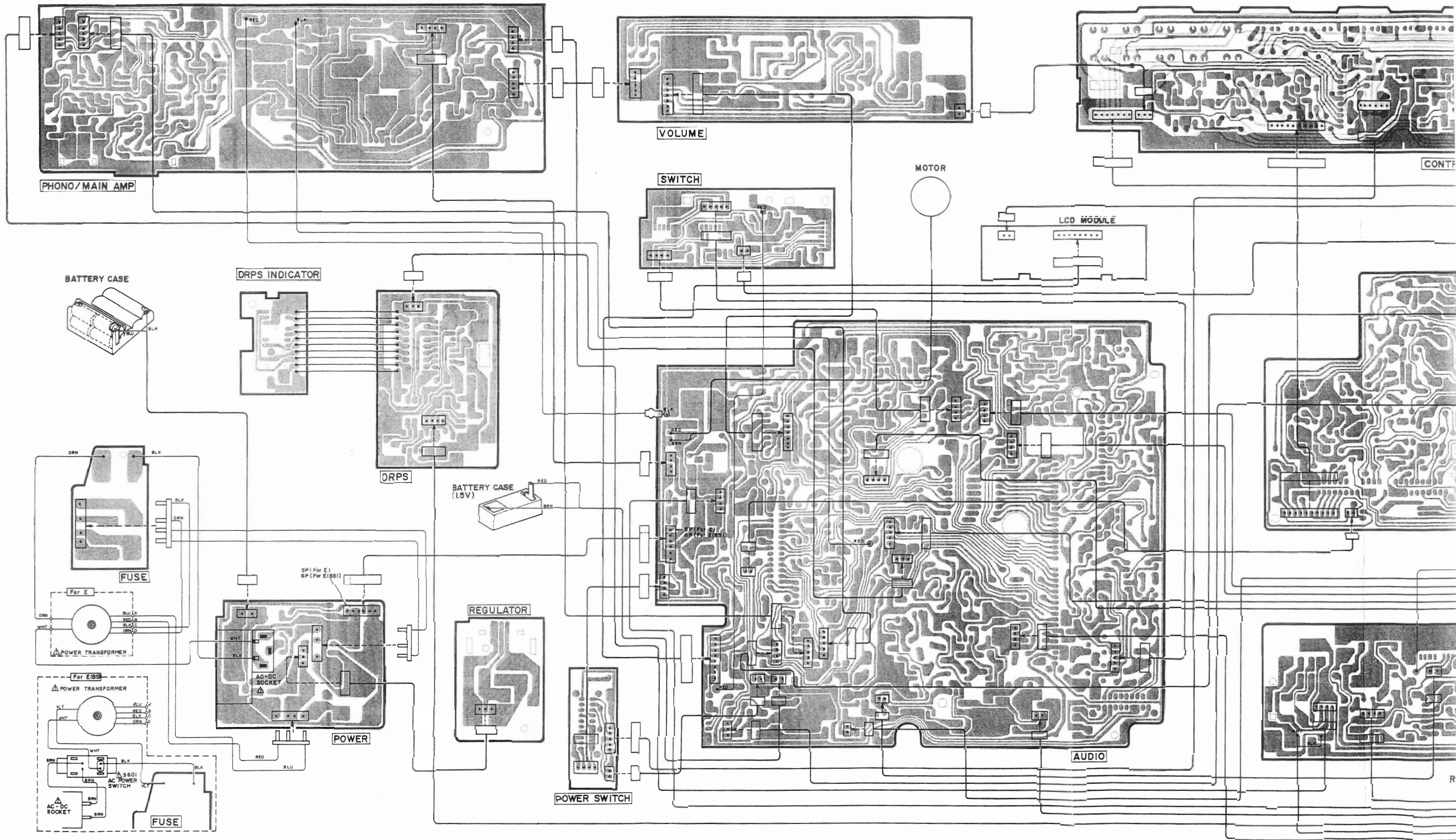

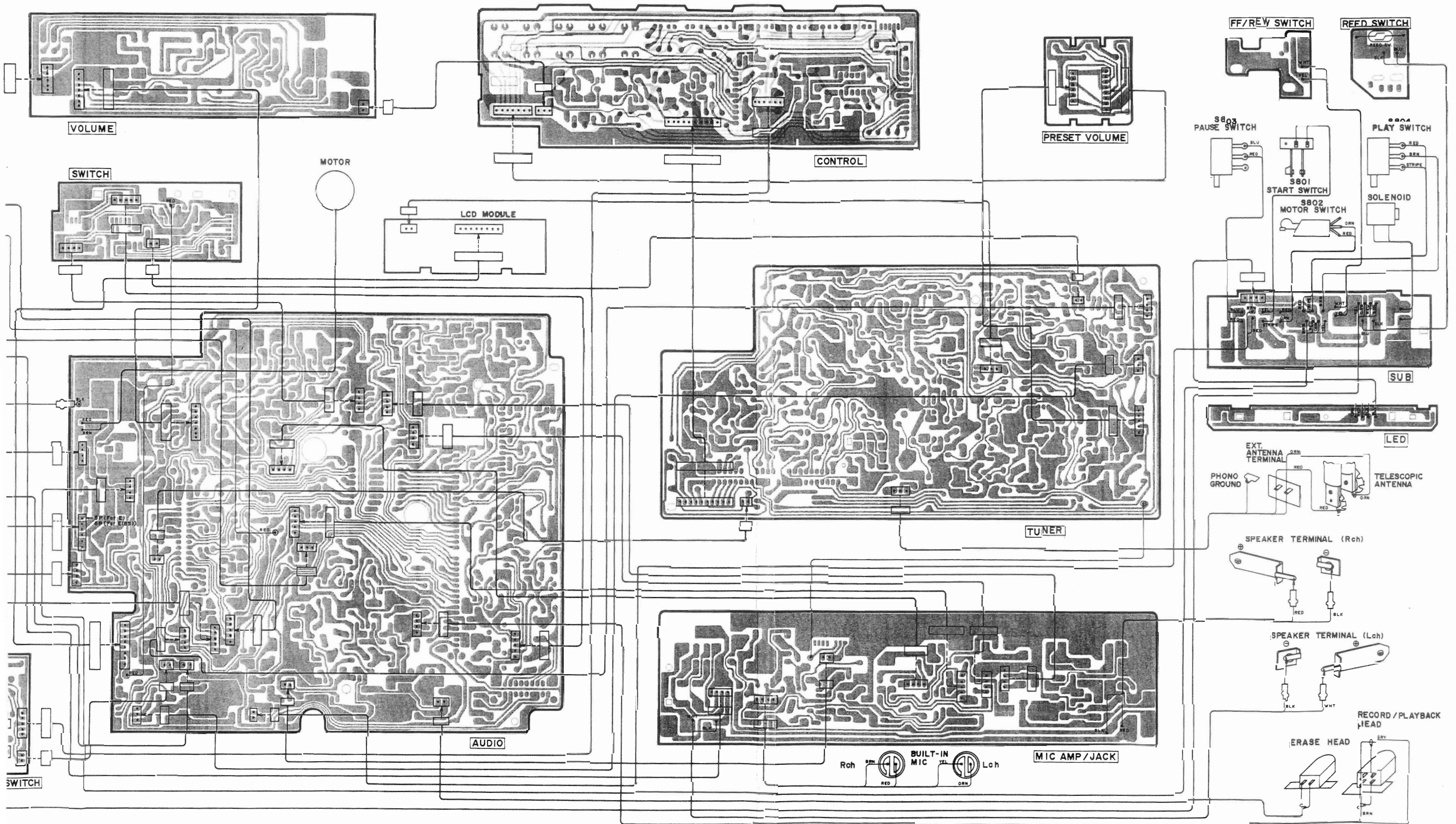

BLOCK DIAGRAM

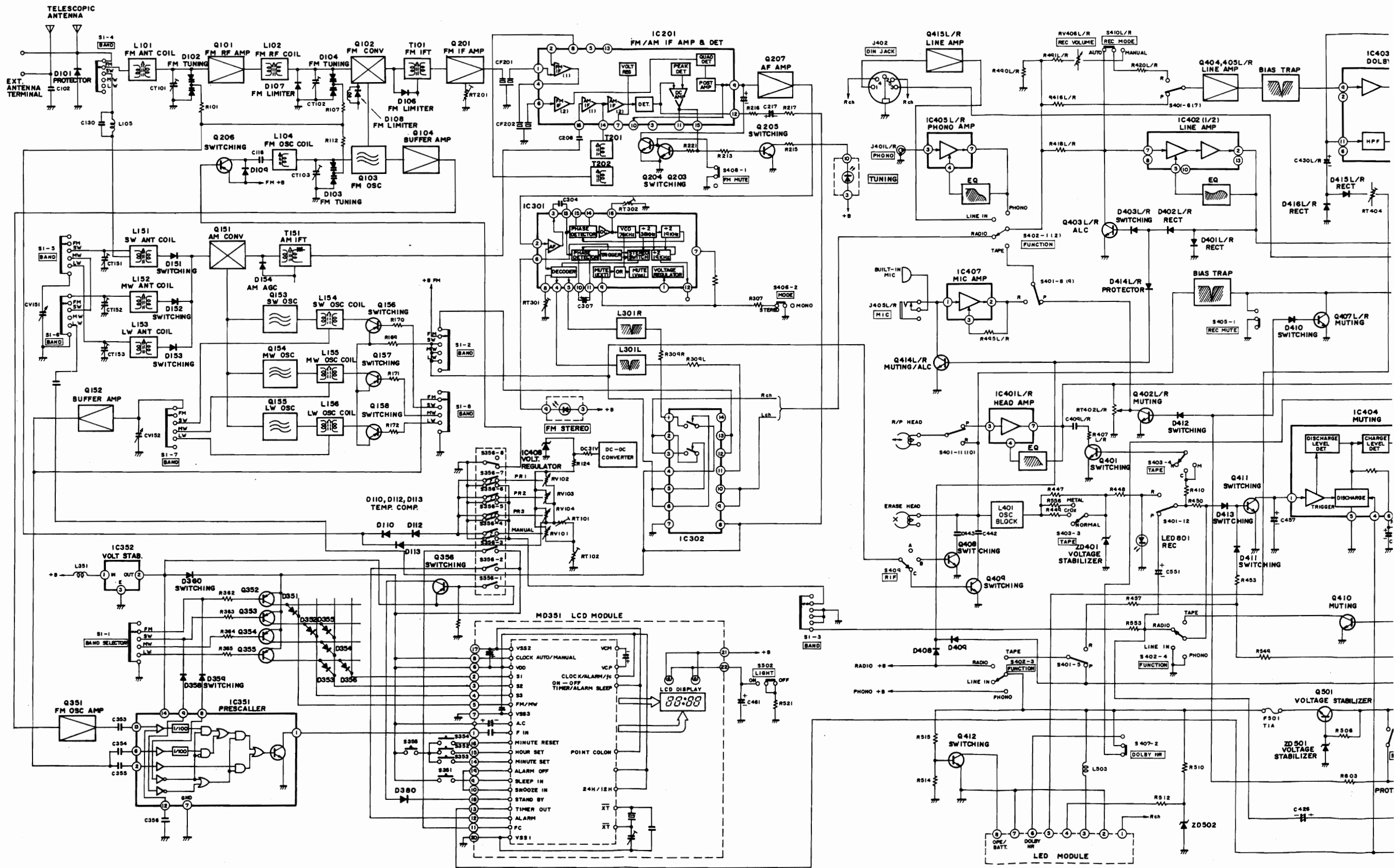

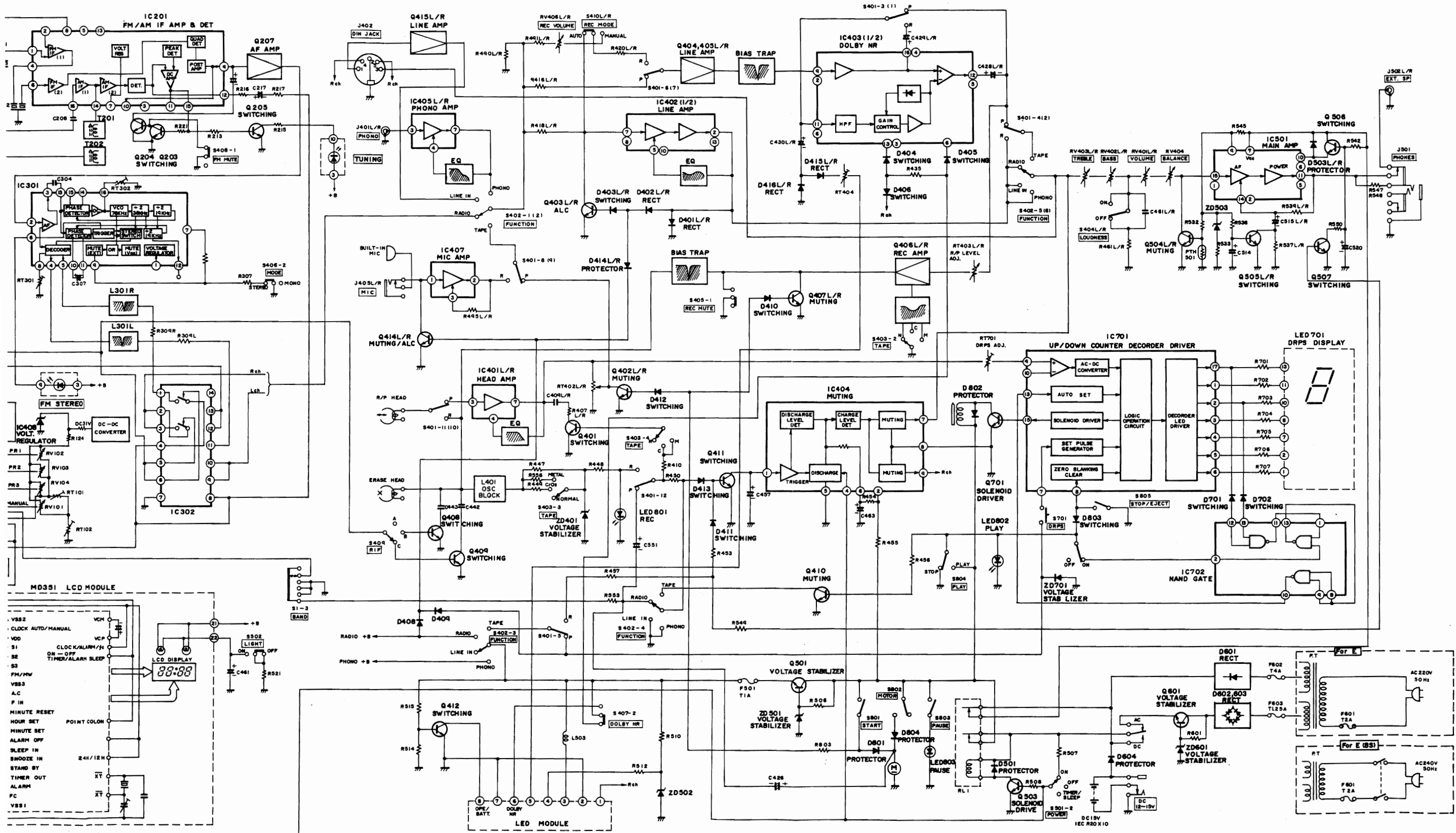

REPLACEMENT PARTS LIST

EXPLODED VIEW (Mechanism-ML-2B)

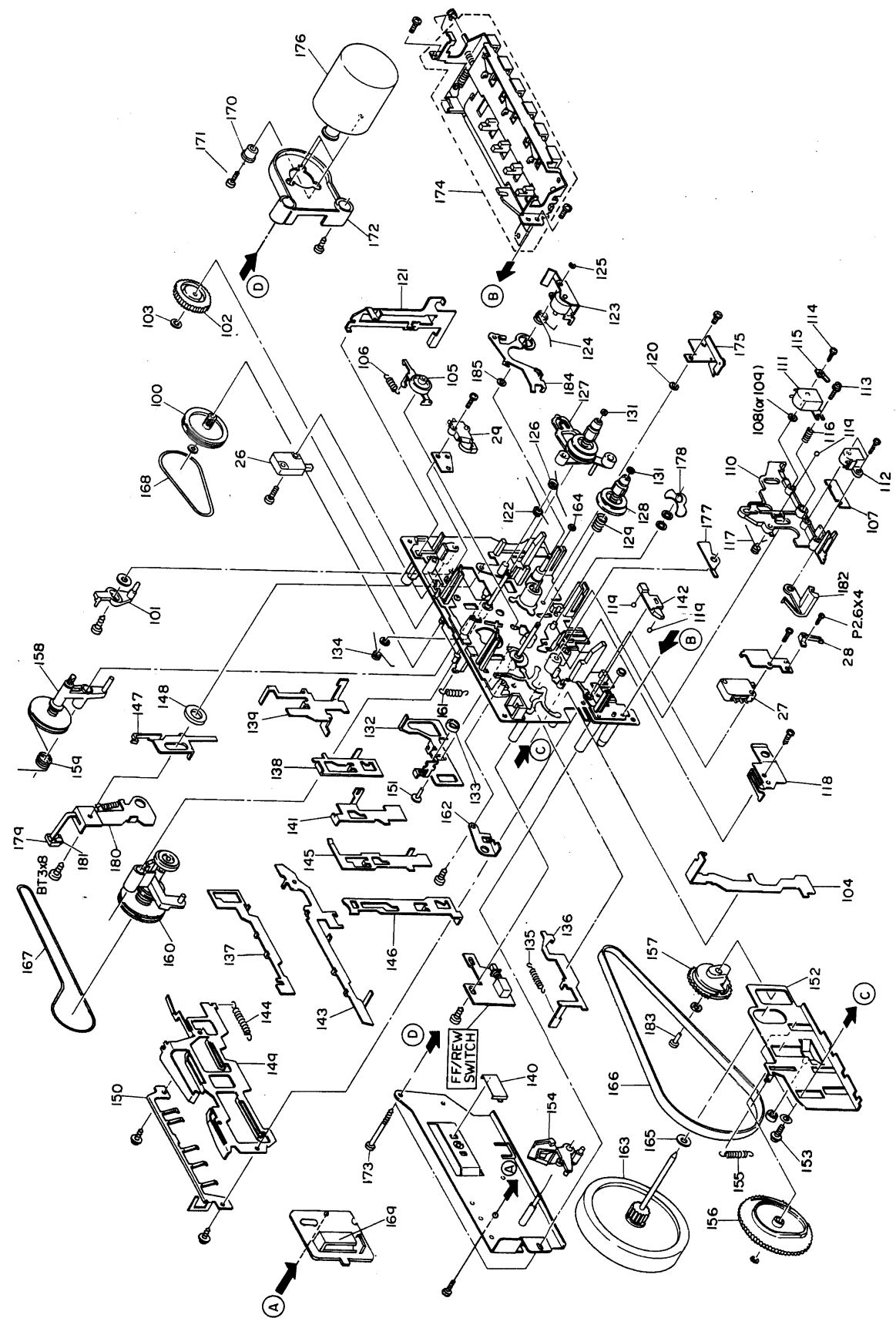

SYMBOL-NO	P-NO	DESCRIPTION	SYMBOL-NO	P-NO	DESCRIPTION
FOR CASSETTE DECK ASSEMBLY (ML-2B)					
100	6430982	PULLEY GEAR FOR AUTO STOP	146	7339061	RECORD SLIDER
101	6762743	AUTO STOP ARM	147	7331698	PICK UP LEVER FOR AUTO STOP
102	6430311	CAM GEAR	148	7787951	WASHER
103	7786115	POLYESTER WASHER	149	6535111	SPRING
104	7331667	RECORD PREVENTION SLIDER	150	6534269	SPRING
105	6762724	FF ARM ASSEMBLY	151	6758322	ARM PIN
106	6540702	SPRING	152	7331877	POWER ASSIST SLIDER ASSEMBLY
107	7757051	SPACER	153	7781135	BT SCREW-3MMD
108	7771441	WASHER - 2 MMD	154	6765597	POWER ASSIST LOCK ARM
109	7771442	WASHER-2MMD	155	6542021	SPRING FOR POWER ASSIST
110	6765466	HEAD PLATE	156	6431119	POWER ASSIST GEAR
111	5449022	RECORD PLAYBACK HEAD	157	6430975	PAUSE GEAR
112	5445352	ERASE HEAD	158	6762674	TAKE UP ARM ASSEMBLY
113	7781005	SCREW FOR HEAD MOUNTING	159	6546453	SPRING FOR TAKE UP ARM
114	8784138	BIND TAPPING SCREW-2MMDX8MM	160	6762644	REWIND ARM ASSEMBLY
115	7317371	EARTH PLATE	161	6301704	SPRING
116	6321733	HEAD SPRING C	162	7333964	REWIND HOLDER
117	6546916	HEAD PLATE SPRING	163	6373792	FLYWHEEL ASSEMBLY
118	6534245	HEAD PLATE HOLDER SPRING	164	7786623	POLY SLIDER WASHER
119	0948492	BALL - 2MMD	165	7772623	SPRING
120	7786172	POLYESTER WASHER	166	6357163	FLYWHEEL BELT
121	7331806	EJECT SLIDER	167	6354531	FLYWHEEL BELT
122	6546518	SPRING FOR EJECT SLIDER	168	6355382	BELT
123	7329781	PRESSURE ROLLER ARM ASSEMBLY	169	5643044	MAGNET
124	6546862	SPRING FOR PRESSURE ROLLER	170	6768891	COLLAR
125	7786219	POLYESTER WASHER	171	8650905	SCREW WITH SPRING WASHER-2.6MMDX5MM
126	6546972	SPRING	172	6762704	MOTOR HOLDER
127	6414233	TURNTABLE ASSEMBLY (TAKE UP)	173	7781147	BT BIND HEAD SCREW-3MMDX30MM
128	6414021	TURNTABLE ASSEMBLY	174	7338174	BUTTON HOLDER ASSEMBLY
129	6520352	BACKTENSION SPRING	175	7334764	STOP ARM ASSEMBLY
131	7786115	POLYESTER WASHER	176	5576854	DC MOTOR ASSEMBLY
132	7331676	BRAKE PLATE	177	7336902	REVIEW LEVER
133	6586007	BRAKE RUBBER	178	7336921	CUE LEVER
134	6546562	SPRING FOR BRAKE PLATE	179	6560481	RUBBER FOR MAGNET
135	6322501	PRESSURE RETURN SPRING	180	7338132	SWITCH ARM ASSEMBLY
136	7331733	SWITCH SLIDER	181	6534862	MAGNET HOLDER
137	7337195	AUTO STOP PREVENTION ASSEMBLY	182	6766442	RECORD STOPPER
138	7337127	FF SLIDER	183	7552442	PIN
139	7331786	PAUSE SLIDER	184	7339302	HEAD PLATE RETURN LEVER
140	6530925	FLYWHEEL SUPPORT SPRING	185	7787027	POLY SLIDER WASHER
141	7339471	PLAY SLIDER			
142	6765041	BALL SUPPORT			
143	7331837	LOCK PLATE			
144	6342222	SPRING			
145	7331759	REWIND SLIDER			

Note: Components marked without numbers in this drawing are not specified as replacement parts.